

---

# EUROPEAN Journal of Physical Education and Sport

---

Has been issued since 2013.  
E-ISSN 2409-1952  
2018. 6(2). Issued 2 times a year

## EDITORIAL BOARD

**Dr. Bartik Pavol** – Matej Bel University, Banská Bystrica, Slovakia (Editor-in-Chief)  
**Dr. Malinauskas Romualdas** – Lithuanian Academy of Physical Education, Kaunas, Lithuania (Deputy Editor-in-Chief)  
**Dr. Khodasevich Leonid** – Sochi State University, Sochi, Russian Federation  
**Dr. Maslovskii Evgenii** – Academy of Physical Culture and Sport, Minsk  
**Dr. Mathivanan D.** – St. Eugene University, Lusaka, Zambia  
**Dr. Pavlovic Ratko** – Faculty of Physical Education and Sport, University of East Sarajevo, Bosnia and Herzegovina  
**Dr. Polustruev Aleksei** – Center for Regenerative Medicine and Rehabilitation, Omsk, Russian Federation  
**Dr. Shakhanova Angelina** – Adyghe State University, Maikop, Russian Federation  
**Dr. Smolensky Andrei** – Russian State University of Physical Culture, Sport, Youth and Tourism, Moscow, Russian Federation  
**Dr. Zeng Howard** – Brooklyn College of The City University of New York, USA

Journal is indexed by: **CrossRef** (UK), **Electronic scientific library** (Russia), **European Reference Index for the Humanities and the Social Sciences** (ERIH PLUS) (Norway), **Global Impact Factor** (Australia), **Open Academic Journals Index** (Russia), **ULRICH's WEB** (USA).

All manuscripts are peer reviewed by experts in the respective field. Authors of the manuscripts bear responsibility for their content, credibility and reliability.

Editorial board doesn't expect the manuscripts' authors to always agree with its opinion.

Postal Address: 1367/4, Stara Vajnorska str., Bratislava – Nove Mesto, Slovakia, 831 04 Release date 05.09.18.

Website: <http://ejournal7.com/> Headset Georgia.  
E-mail: [ejm2013@mail.ru](mailto:ejm2013@mail.ru)

Founder and Editor: Academic Publishing House Researcher s.r.o. Order № 18.

**European Journal of Physical Education and Sport**

2018

Is. **2**

## C O N T E N T S

**Articles and Statements**

Opinions of Teachers on Teaching Non-Traditional Sports in Primary Schools Š. Adamčák, P. Bartík, A. Kozaňáková, R. Tomková .....	40
The Impact of Physical Programs to the Level of Muscle Imbalance in Pupils of the 8 <sup>th</sup> Grade at Primary School M. Knechta .....	50
The Intensification of Speed-Power Ability Control of Basketball Players V. Koryahin, O. Blavt, E. Bezgrebelnaya .....	55
Level of Students' Posture in Adolescence in Relation to Physical Activity M. Marko, R. Rozim, P. Kurková, E. Bendíková .....	61
The Effect of a 10-Week Health Education Program on the Prevention of Injuries in Students With Special Needs C. Mavrovounioti, E. Argiriadou, A.Mavrovouniotis, A. Praskidou, A. Kansizoglou, I. Proios, F. Mavrovouniotis .....	68
Exploring of Youth Volleyball Players' Engagement Motivations and Health Related Behaviors H.Z. Zeng .....	80

Copyright © 2018 by Academic Publishing House Researcher s.r.o.



Published in the Slovak Republic  
European Journal of Physical Education and Sport  
Has been issued since 2013.  
E-ISSN: 2409-1952  
2018, 6(2): 40-49

DOI: 10.13187/ejpe.2018.2.40  
[www.ejournal7.com](http://www.ejournal7.com)

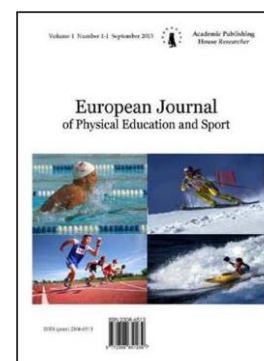

## Articles and Statements

### Opinions of Teachers on Teaching Non-Traditional Sports in Primary Schools

Štefan Adamčák <sup>a</sup>, Pavol Bartík <sup>a,\*</sup>, Anna Kozaňáková <sup>b</sup>, Renáta Tomková <sup>c</sup>

<sup>a</sup> Matej Bel University, Slovakia

<sup>b</sup> Academy of the Police Force in Bratislava, Slovakia

<sup>c</sup> Elementary school with a nursery school in Pavlovce nad Uhom, Slovakia

#### Abstract

The study aims to analyse the opinions of primary school teachers (n=324) on teaching non-traditional sports in terms of the school's location (urban/rural), as well as in terms of intersexual differences. The research was carried out in the school year 2015/16 and the opinions were collected in a survey and evaluated using the TAP 3 program of Gamo, Banská Bystrica. The majority of teachers (87.96 %) hold the view that interest in Physical Education and Sport will increase through the teaching of non-traditional sports. According to the teachers, when it comes to non-traditional sports, both in urban and rural schools, the students are most interested in floorball (boys) and badminton (girls). The most motivating factor for pupils when implementing non-traditional sports is, according to the teachers, the stimulation of skills and abilities through the sports. This answer significantly dominates among all teachers in the urban schools – with a response frequency higher than 60 %.

**Keywords:** sports, non-traditional sports, school Physical Education, teacher of Physical Education and Sport.

#### 1. Introduction

Building on the constantly changing interest of pupils in Physical Education and Sport, the interest in new activities which are mostly used for leisure purposes is increasing. Implementing non-traditional physical or sport activities brings new motivations for pupils and teachers to make teaching more attractive and the content of Physical Education and Sport more varied. This fact is related to their high emotionality and diversity in terms of performing movements, as well as to the high diversity of equipment (Bláha, 2005). According to Pohájacká (2011), sports represent the most natural activity in children's lives, through which they absorb a great number of impulses, knowledge, and experiences into their own consciousness.

Satisfied pupils should be the ambition of all teachers. The pupil must actively take part in the educational process to be successful in it. Considering the low, or even absent, inner motivation of pupils, outside motivation from the teacher, whose role is to actively engage them in individual activities, is very important, especially in terms of prevention of undesirable social phenomena

\* Corresponding author

E-mail addresses: [pavol.bartik@umb.sk](mailto:pavol.bartik@umb.sk) (P. Bartík), [stefan.adamcak@umb.sk](mailto:stefan.adamcak@umb.sk) (Š. Adamčák)

(Verešová, 2004). According to Roučková, Argajová (2013), it is the emotional side of the physical education process and the elimination of stereotypes in the teachers' activities which have a positive response among pupils.

The most important factor, when implementing and realising non-traditional sports, is the teacher's personality, their willingness and sensitive approach in the selection of exercises and sports, through which they will achieve a gradual development of the pupils' competences in accordance with the chosen physical activity (Adamčák, 2013). An active, creative, and flexible teacher, who knows their subject and pupils, can make teaching more attractive and build on the pupils' knowledge, on what they find interesting, and what is natural and attractive to them. We identify with the opinion of Chromík et al. (1993), that teachers are the most important factor of the educational process, because they provide the pupils with information and, at the same time, influence the development of their personality.

The research aims to ascertain the current state of non-traditional sports in primary schools in the urban and rural schools in the Košice region.

## 2. Materials and methods

The survey sample consisted of 324 teachers, who teach Physical Education and Sport in the second level of primary schools in the Košice region. Out of the total, 176 (104 males and 72 females) were teachers in urban schools and 148 (85 males and 63 females) were teachers in rural schools. Their detailed characteristics are stated in Table 1. We used the interrogative method – survey – as a central method in our research.

**Table 1.** The characteristics of the survey sample of teachers in terms of locality

District	Urban			Rural			Average values urban – rural
	Male	Female	Average values urban M-F	Male	Female	Average values rural M-F	
Gelnica	4.80 %	5.55 %	5.11 %	4.70 %	4.76 %	4.72 %	4.93 %
Košice I.	20.19 %	15.27 %	18.18 %	0.0 %	0.0 %	0.0 %	9.87 %
Košice II.	24.03 %	20.83 %	22.72 %	0.0 %	0.0 %	0.0 %	12.34 %
Košice III.	7.69 %	9.72 %	8.52 %	0.0 %	0.0 %	0.0 %	4.62 %
Košice IV.	18.26 %	11.11 %	15.34 %	0.0 %	0.0 %	0.0 %	8.33 %
Košice-okolie	0.0 %	6.94 %	2.84 %	30.58 %	34.92 %	32.43 %	16.35 %
Michalovec	4.80 %	12.5 %	7.95 %	20.0 %	34.92 %	26.35 %	16.35 %
Rožňava	4.80 %	2.77 %	3.97 %	10.58 %	9.52 %	10.13 %	6.79 %
Sobrance	2.88 %	1.38 %	2.27 %	9.41 %	34.76 %	7.43 %	4.62 %
Spišská Nová Ves	6.73 %	6.94 %	6.81 %	18.82 %	7.93 %	14.18 %	10.18 %
Trebišov	5.76 %	6.94 %	6.25 %	5.88 %	3.17 %	4.72 %	5.55 %

Results were processed by a percentage frequency analysis and, at the same time, evaluated by the Chi-squared test levels  $p < 0.01$  and  $p < 0.05$  from the aspect of locality (urban-rural), as well as gender differences.

## 3. Results

In the first survey question, we asked which sport activities pupils prefer during Physical Education and Sport. The findings presented in (T2) point to the fact that pupils of urban and rural schools unequivocally prefer traditional sport activities during PE classes. The foregoing correlates with the research done by Slezák and Melicher (2008), who found that boys mainly prefer football in primary schools and basketball in higher grades. Girls are mostly interested in volleyball. Considering the responses, we predicted that non-traditional sports would gain a higher percentage, which was not confirmed. One of the reasons, based on our experience, could be, that,

if we offer a new non-traditional activity to pupils, the younger pupils will show curiosity and high initial interest. If they do not identify with the activity yet (they have not become accustomed to it) the initial euphoria quickly fades away and they go back to the “good-old” traditional sports.

**Table 2.** Pupils’ interest in non-traditional sports in PE classes

Locality	Urban			Rural			Average values urban – rural
	Male	Female	Average values urban M-F	Male	Female	Average values rural M-F	
Traditional sport activities	83.65 %	72.22 %	<b>78.97 %</b>	89.41 %	77.77 %	<b>84.45 %</b>	<b>81.48 %</b>
Non-traditional sport activities	10.57 %	22.22 %	<b>15.34 %</b>	8.23 %	20.63 %	<b>13.51 %</b>	<b>14.50 %</b>
Not interested in sport activities	5.76 %	5.55 %	<b>5.68 %</b>	2.35 %	1.58 %	<b>2.02 %</b>	<b>4.01 %</b>

We find it appropriate to regularly return to traditional sports while gradually introducing and offering something new to pupils. In our opinion, we should offer pupils as much information and experience as possible, so they can choose activities they will follow throughout their lives, and help them create a lifelong relationship with physical activities, which are (often unintentionally) then passed on to the next generation, and by that fulfil the fundamental aim of PE. The fact that 4.01% of pupils do not show interest in any sports is worrying. Pupils in rural areas show more interest in sport activities than those in urban areas. The following findings are from research by Betka (2012) on the popularity of sports for leisure purposes: volleyball has become the favourite sport, selected by 25 % of pupils, the second favourite was football, also selected by 25 %, and floorball was in third place with 14 %. Floorball is now commonly played in PE classes, constantly gaining greater popularity, and therefore we no longer include it among non-traditional sports. This has also been confirmed by Antala et al. (2012) and Adamčák – Nemeč (2014).

Statistically significant differences at level  $p < 0.05$  were only recorded in terms of gender differences. Women, without distinction to locality, lean more towards non-traditional sports.

**Table 3.** Statistical evaluation of pupils’ interest in non-traditional sports in PE classes

Item	Male Urban – Rural	Female Urban – Rural	Urban Male – Female	Rural Male – Female	Average value Urban – Rural
Statistical significance Chi-squared	<b>N (0.419)</b>	<b>N (0.448)</b>	<b>X (0.10)</b>	<b>X (0.09)</b>	<b>N (0.206)</b>

Legend: **xx** = statistical significance – level  $p < 0.01$ , **x** = statistical significance – level  $p < 0.05$ , **N** = statistically insignificant

Research done by Biddle, Soos, Hamar, et al. (2009), Nemeč-Nemcová, (2012), Beták, (2014), and others, point to the need for increasing the physical activity of children, as well as the fact that motivating pupils towards regular physical activity and Physical Education itself is more and more difficult (Kazimírová, 2008). That is why, when we were putting the survey together, we were mostly interested in whether the implementation of non-traditional sports really contributes to the increase of interest in Physical Education and Sport. The answers which we collected in the second survey question (T4) confirmed our predictions that 87.96 % of teachers think that interest in Physical Education and Sport will increase through non-traditional sports. On the other hand, about 2.16 % held a negative opinion and up to 5.55 % thought that the interest in Physical Education and Sport will not increase through non-traditional sports. About 6.48 % of teachers

were indifferent to the question “whether the implementation of non-traditional sports contributes to the increase of interest in Physical Education and Sport.” We consider our results to be positive and motivational, because we lean towards the opinion of Lafka (2010), that non-traditional sports have an undeniably positive influence on Physical Education and Sport, and due to their implementation, the pupils showed higher interest in physical activities during Physical Education and Sport.

**Table 4.** The rate of interest increase in Physical Education and Sport through non-traditional sports

Locality	Urban			Rural			Average values Urban – Rural
	Male	Female	Average values Urban M-F	Male	Female	Average values Rural M-F	
Yes	88.46 %	90.27 %	<b>89.20 %</b>	87.05 %	85.71 %	<b>86.48 %</b>	<b>87.96 %</b>
No	4.80 %	5.55 %	<b>5.11 %</b>	5.88 %	6.34 %	<b>6.08 %</b>	<b>5.55 %</b>
Cannot asses	6.73 %	4.16 %	<b>5.68 %</b>	7.05 %	7.93 %	<b>7.43 %</b>	<b>6.48 %</b>

The teachers’ answers in terms of gender differences (T5) and locality were very balanced and therefore we did not record any statistically significant differences in the answers.

**Table 5.** Statistical evaluation of the rate of interest increase in Physical Education and Sport through non-traditional sports

Item	Male Urban – Rural	Female Urban – Rural	Urban Male – Female	Rural Male – Female	Average value Urban – Rural
<b>Statistical significance Chi-squared</b>	<b>N (0.939)</b>	<b>N (0.63)</b>	<b>N (0.757)</b>	<b>N (0.971)</b>	<b>N (0.744)</b>

Legend: **xx** = statistical significance – level  $p < 0.01$ , **x** = statistical significance – level  $p < 0.05$ , **N** = statistically insignificant

In the next question (T6) we asked which non-traditional sports are more attractive for boys from the teachers’ point of view in terms of intersexual differences. Considering the higher number of possible answers, the teachers could choose from a wider range of answers and they were required to state three most suitable non-traditional sports for boys. We noticed significant differences in the opinions of male and female teachers. While about 35 % of males selected mostly floorball and then badminton, about the same % of females selected mostly badminton and then floorball. The reason could be the teachers’ individual relationship towards the physical activities. Our discoveries follow the works of Bláha, (1998), Krška, (2007), and Nemeč, (2008), who point to the fact that sports as floorball, ringo, badminton, speedminton, and many others, are becoming common in school Physical Education. The third place belongs to streetball – the frequency of answers in urban schools was slightly lower. Foot volleyball came in the fourth place (average value – 7.81 %). This is where the opinions of teachers differ in terms of their gender.

**Table 6.** Attractiveness of non-traditional sports for boys from teachers' point of view

Locality	Urban			Rural			Average values
	Male	Female	Average values urban M-F	Male	Female	Average values rural M-F	
Floorball	34.93 %	28.24 %	<b>32.19 %</b>	36.07 %	20.63 %	<b>29.50 %</b>	<b>30.96 %</b>
Badminton	21.47 %	33.33 %	<b>26.32 %</b>	22.74 %	36.50 %	<b>28.60 %</b>	<b>27.36 %</b>
Streetball	13.78 %	11.57 %	<b>12.87 %</b>	16.07 %	14.81 %	<b>15.54 %</b>	<b>14.09 %</b>
Foot volleyball	9.29 %	8.79 %	<b>9.90 %</b>	6.27 %	6.34 %	<b>6.30 %</b>	<b>7.81 %</b>
Ultimate frisbee	7.37 %	3.70 %	<b>5.87 %</b>	3.92 %	5.82 %	<b>4.73 %</b>	<b>5.34 %</b>
Softball	4.80 %	1.85 %	<b>3.59 %</b>	4.31 %	6.87 %	<b>5.40 %</b>	<b>4.42 %</b>
Ringo	3.20 %	9.25 %	<b>5.68 %</b>	6.27 %	4.23 %	<b>5.40 %</b>	<b>5.55 %</b>
Speedminton	2.88 %	1.85 %	<b>2.46 %</b>	2.74 %	2.11 %	<b>2.47 %</b>	<b>2.46 %</b>
Lacrosse	1.60 %	0.92 %	<b>1.32 %</b>	0.39 %	0.25 %	<b>0.45 %</b>	<b>0.92 %</b>
Indiaca – peteca	0.64 %	0.46 %	<b>0.56 %</b>	1.17 %	2.11 %	<b>1.57 %</b>	1.02 %

While male teachers in urban schools were mostly interested in foot volleyball, and those in rural schools in foot volleyball and ringo, female teachers gave preference to ringo and softball. Based on the average values, these are the sports that follow: ringo, ultimate frisbee, softball. According to the teachers, the least appropriate non-traditional sports for boys are: lacrosse, indiaca – peteca, and speedminton. We recorded 0% for the answer “non-traditional sports are not suitable for Physical Education and Sport”. Teachers did not select the option “other”.

**Table 7.** Statistical evaluation of attractivity of non-traditional sports for boys from teachers' point of view

Item	Male Urban – Rural	Female Urban – Rural	Urban Male – Female	Rural Male – Female	Average value Urban – Rural
Statistical significance Chi-squared	<b>XX (0.000001)</b>	<b>XX (0.0000026)</b>	<b>XX (0.0000020)</b>	<b>XX (0.0000014)</b>	<b>XX (0.0000000000177)</b>

Legend: **xx** = statistical significance – level  $p < 0.01$ , **x** = statistical significance – level  $p < 0.05$ , **N** = statistically insignificant

Some inconsistency in answers in terms of gender differences and locality (T7) manifested itself at a statistical significance level  $p < 0.01$ .

In the next question (T8) we asked which non-traditional sports are more attractive for girls from the teachers' point of view in terms of gender differences. In this question, the teachers could also choose from a wider range of answers and were required to state three non-traditional sports most suitable for girls.

**Table 8.** Attractivity of non-traditional sports for girls from the teachers' point of view

Locality	Urban			Rural			Average values
	Male	Female	Average values Urban M-F	Male	Female	Average values rural M-F	
Badminton	34.93 %	42.59 %	<b>38.06 %</b>	44.31 %	27.51 %	<b>37.16 %</b>	<b>37.65 %</b>
Floorball	23.71 %	19.44 %	<b>21.97 %</b>	21.17 %	18.51 %	<b>20.04 %</b>	<b>21.09 %</b>
Streetball	11.53 %	6.48 %	<b>9.470 %</b>	6.27 %	11.64 %	<b>8.55 %</b>	<b>9.05 %</b>
Ringo	5.76 %	10.18 %	<b>7.57 %</b>	10.58 %	8.46 %	<b>9.68 %</b>	<b>8.53 %</b>
Ultimate frisbee	14.42 %	8.33 %	<b>11.93 %</b>	9.80 %	14.81 %	<b>11.93 %</b>	<b>11.93 %</b>
Speedminton	5.12 %	5.09 %	<b>5.11 %</b>	1.17 %	5.82 %	<b>3.15 %</b>	<b>4.21 %</b>
Softball	2.24 %	2.77 %	<b>2.46 %</b>	0.39 %	7.40 %	<b>3.37 %</b>	<b>2.88 %</b>
Lacrosse	1.28 %	2.31 %	<b>1.70 %</b>	3.13 %	2.64 %	<b>2.92 %</b>	<b>2.26 %</b>
Foot volleyball	0.64 %	1.85 %	<b>1.13 %</b>	51.96 %	2.11 %	<b>2.02 %</b>	<b>1.54 %</b>
Indiaca – peteca	0.32 %	0.92 %	<b>0.56 %</b>	1.17 %	1.05 %	<b>1.12 %</b>	<b>0.82 %</b>

Legend: n = total number, % = percentage

The teachers of urban (38.06%), as well as rural (37.16%) schools, without any gender differences, agreed that the most appropriate non-traditional sport for girls is badminton. Antala et al. (2012) also discovered a high popularity rate of badminton among individual sport activities of girls. The second most favourite sport is floorball, with 21.09 %, which, according to Skružný et al. (2015), is because it is a very dynamic sport with lots of twists and turns. The third place belongs to ultimate frisbee (11.93 %) which is undemanding for space and allows lots of modifications (accuracy, couples, distance, etc.) (Argaj, 2004). Female teachers in urban schools and male teachers in rural schools are an exception and lean more towards streetball and ringo. From the teachers' perspective, the least appropriate sport for girls is indiaca-peteca, except for male teachers in rural schools, who consider softball to be the least appropriate for girls, followed by foot volleyball. Just as with boys, we recorded 0% for the answer "non-traditional sports are not suitable for Physical Education and Sport". Teachers have not marked the option "other".

**Table 9.** Statistical evaluation of attractivity of non-traditional sports for girls from the teachers' point of view

Item	Male Urban – Rural	Female Urban – Rural	Urban Male – Female	Rural Male – Female	Average value Urban – Rural
Statistical significance Chi-squared	<b>XX</b> (0.0000000087)	<b>XX</b> (0.000036)	<b>XX</b> (0.00001)	<b>XX</b> (0.0000000037)	<b>XX</b> (0.00000000155)

Legend: **xx** = statistical significance – level  $p < 0.01$ , **x** = statistical significance – level  $p < 0.05$ , **N** = statistically insignificant

In this case, as well as with boys, the mentioned inconsistency of answers in terms of gender differences and locality (T<sub>9</sub>) has manifested itself on a statistical significance level  $p < 0.01$ .

The most motivating factor in implementing non-traditional sports was based on the main steps of teachers' activities when implementing the sports, according to Argaj (2014), which are the



name, aim, theme, rules, division, decision-making, and assessment of the sport. By averaging the results, we found that the theme (stimulation of skills and abilities through the game) was the most frequent answer, significantly dominating in urban schools among both the male (62.50 %) and the female teachers (63.88 %), and in urban schools with an average value of 52.02 %.

**Table 10.** Motivational factor in teaching non-traditional sports from the pupils' point of view

Locality	Urban			Rural			Average values
	Male	Female	Average values Urban M-F	Male	Female	Average values rural M-F	
Theme	62.50 %	63.88 %	<b>63.06 %</b>	49.41 %	55.55 %	<b>52.02 %</b>	<b>58.02 %</b>
Equipment	21.15 %	18.05 %	<b>19.88 %</b>	31.76 %	17.46 %		<b>22.53 %</b>
Rules	5.76 %	12.50 %	<b>8.52 %</b>	16.47 %	25.39 %		<b>25.67 %</b>
Name	10.57 %	5.55 %	<b>8.52 %</b>	2.35 %	1.58 %	<b>2.02 %</b>	<b>20.27 %</b>

The second most frequent answer was equipment (agreed on by almost all respondents), which, according to Chovanová (2005), is one of the factors that can positively influence the Physical Education process – increase the attractivity, effectivity, and aesthetics of exercises or sports.

A group of female teachers in rural schools were an exception when they suggested that the sport's rules are the most motivating factor for pupils. We discovered from the answers (T10) that the least important, interesting, or attractive factor for pupils is the name of the sport. Male teachers in urban schools were an exception - according to them the least attractive and motivating are the sport's rules.

**Table 11.** Statistical evaluation of the motivational factor in teaching non-traditional sports from the pupils' point of view

Item	Male Urban – Rural	Female Urban – Rural	Urban Male – Female	Rural Male – Female	Average value Urban – Rural
<b>Statistical significance Chi-squared</b>	<b>XX (0.004)</b>	<b>N (0.083)</b>	<b>N (0.291)</b>	<b>N (0.197)</b>	<b>XX (0.0007)</b>

Legend: **xx** = statistical significance – level  $p < 0.01$ , **x** = statistical significance – level  $p < 0.05$ , **N** = statistically insignificant

The differences in motivational factors have manifested at statistical significance (T11) level  $p < 0.01$  among the male teachers of urban and rural schools, as well as in the average values of urban and rural schools. In the remaining evaluations, we recorded statistically insignificant values.

In the last question of our survey we asked how the teachers perceive the implementation of non-traditional sports under the compulsory elective thematic unit of Physical Education and Sport classes.

**Table 12.** The interest of teachers in including non-traditional sports in the compulsory elective thematic unit

Locality	Urban			Rural			Average values
	Male	Female	Average values urban M-F	Male	Female	Average values rural M-F	
Positive	91.34 %	94.44 %	<b>92.61 %</b>	92.94 %	95.23 %	<b>93.91 %</b>	<b>93.20 %</b>
Negative	2.88 %	1.38 %	<b>2.27 %</b>	2.35 %	1.58 %	<b>2.02 %</b>	<b>2.16 %</b>
Could not assess	5.76 %	4.16 %	<b>5.11 %</b>	4.70 %	3.17 %	<b>4.05 %</b>	<b>4.62 %</b>

By averaging the stated values (T12) we can see, that on average 93.20 % of urban (92.10 %) and rural (93.31 %) school teachers have a positive attitude towards the implementation of non-traditional sports in Physical Education and Sport. Considering the combined figures, we can unequivocally state that the implementation of non-traditional sport in Physical Education and Sport undoubtedly has a positive influence. It is worth mentioning here, that those teachers who do not have sufficient knowledge of non-traditional sports should update their knowledge in order to be able to implement not only the sports into their educational process, but also the preparatory exercises, game exercises, and preparatory games, and be able to fulfil the aims of Physical Education and Sport better, as stated by, e.g. Baránek (2014). We also agree with Hájková (2007), who states that the first and foremost objective of performing physical and sport activities is the children's safety, which is why practice, perfection, and implementation itself should be adjusted according to age specifics and the space obligations of the sport. On average, 2.16 % of teachers disagreed with this question and 4.62 % were not able to state their opinion.

**Table 13.** Statistical evaluation of the interest of teachers in including non-traditional sports in the compulsory elective thematic unit

Item	Male Urban – Rural	Female Urban – Rural	Urban Male – Female	Rural Male – Female	Average value Urban – Rural
Statistical significance Chi-squared	<b>N (0.921)</b>	<b>N (0.950)</b>	<b>N (0.710)</b>	<b>N (0.845)</b>	<b>N (0.89)</b>

Legend: **xx** = statistical significance – level  $p < 0.01$ , **x** = statistical significance – level  $p < 0.05$ , **N** = statistically insignificant

The respondents' answers, in terms of gender differences, as well as locality, were highly identical and statistically significant differences were not recorded (T13). We know from practice, that sport belongs to the most favourite and widespread physical activities. Hajduková – Uchál' (2009) stress the meaning of sports, and state that we can exercise various abilities through sports, from concentration and delicate movements, through memory and creativity, to social abilities. We can call this a pedagogical contribution. The authors also add that sport can help us to unwind and relax which is the manifestation of a psychological experience.

#### 4. Conclusion

Based on the results of our research, which was only focused at a partial part of the teaching of non-traditional sports in primary schools from the perspective of teachers of Physical Education and Sport, we suggest including non-traditional sports in lessons, even if, according to 78.97 % of

teachers, the pupils prefer traditional sport activities. Up to 87.96 % of the teachers agree that interest of pupils in Physical Education and Sport may increase through non-traditional sports, while the most motivating factors are new skills and abilities gained through the sports, as well as the “new” – non-traditional equipment used in these activities. According to the teachers of urban and rural schools, when it comes to non-traditional sports, the students are most interested in floorball and badminton (both genders), even though the evaluation of these answers showed the biggest statistically significant differences among male and female teachers.

## References

- Adamčák, 2013** – Adamčák, Š. (2013). Názory žiakov 5.-9. ročníka základnej školy na netradičné športové hry. In *Exercitatio corporis - motus – salus 1. Slovenský časopis o vedách a športe*, vol. 5, no. 1, pp. 66-76.
- Adamčák, Nemeč, 2014** – Adamčák, Š., Nemeč, M. (2014). Obľúbenosť športových hier realizovaných na hodinách telesnej a športovej výchovy z pohľadu žiakov mestských a vidieckych základných škôl. *Studia Kínanthropologica*, vol. 15, no. 3, pp. 123-130.
- Antala et al., 2012** – Antala B. et al. (2012). Telesná a športová výchova v názoroch žiakov základných a stredných škôl. NŠC, FTVŠ UK Bratislava: END, spol. s r.o. Topolčianky, 168 p.
- Argaj, 2004** – Argaj, G. (2004). Pohybové hry s lietajúcim diskom. Zborník Národného inštitútu športu rok 2003, Bratislava, pp. 88-98.
- Argaj et al., 2014** – Argaj, G. et al. (2014). Základy didaktiky pohybových hier. Telesná a športová výchova – kolektívne športové činnosti, gymnastike a tanečné pohybové činnosti. Bratislava: Národné športové centrum v spolupráci s Fakultou telesnej výchovy a športu Univerzity Komenského v Bratislave, 264 p.
- Baránek, 2014** – Baránek, D. (2014). Florbal pre žiakov 5. Ročníka základnej školy. *Tel. Vých. In Exercitatio corporis - motus – salus 1, Slovenský časopis o vedách a športe.*, vol. 5, no. 1, pp. 66-76.
- Beťák, 2014** – Beťák, B. (2014). Pohybové a športové aktivity vo voľnom čase žiakov stredných škôl v Poprade. In *Telesná výchova a šport v živote človeka : recenzovaný zborník vedeckých prác*. Zvolen: Technická univerzita, pp. 76-85.
- Biddle et al., 2009** – Biddle, S. J. H., Soos, I., Hamar, P. et al. (2009). Physical activity and sedentary behaviours in youth: Data from three central-eastern European countries. *European Journal of Sport Science*, 9, pp. 295–301.
- Bláha, 1998** – Bláha, L. (1998). Tchoukball – jedna z cest proti agresivite ve sportovních hrách. In: *Těl. Vých. Sport Mlád.*, no. 6, pp. 32-36.
- Hajdúková, Uchál, 2009** – Hajdúková, R., Uchál, J. (2009). Vplyv netradičných športov na rozvoj koordinačných schopností. Prešov: MPC Prešov, 96 p.
- Hájková, 2007** – Hájková, M. (2007). Osobitosti pohybovej aktivity detí, mládeže, žien, seniorov a hendikepovaných športovcov. pp. 100–109. In *Telovýchovné lekárstvo*, Bratislava: Lekárska Fakulta Univerzity Komenského, 265 p.
- Chovanová, 2008** – Chovanová, E. (2008). Intersexuálne rozdiely v somatickom vývine a rozvoji koordinačných schopností 6 – 7 ročných detí vplyvom netradičných cvičení a hier. In: *Zborník prác z Medzinárodnej vedeckej konferencie „Šport a kvalita života 2008“*, Brno, pp. 2–8.
- Chromík et al., 1993** – Chromík, M. et al. (1993). Didaktika telesnej výchovy. Bratislava: Univerzita Komenského Bratislava.
- Kazimírová, 2008** – Kazimírová, G. (2008). Návrh modelu vyučovania florbalu a bedmintonu v predmete telesná výchova na základnej škole. In *Telesná výchova a šport, zdravie a pohyb*. Prešov: MPC Bratislava, alokované pracovisko Prešov, pp. 161-163.
- Krška, 2007** – Krška, P. (2007). Úroveň vybraných florbalových zručností detí mladšieho školského veku. In *Zborník „Telovýchovný proces na školách“*. B. Bystrica: PF UMB a KTV UMB, 105 p.
- Lafko, 2010** – Lafko, V. (2010). Realizácia menej známych a netradičných športových hier na 2. stupni základných škôl. In *Zborník recenzovaných vedeckých príspevkov. Pohybová aktivita v živote človeka pohyb detí*. Prešov : Fakulta športu Prešovskej univerzity, 248 p.
- Nemeč, 2008** – Nemeč, M. (2008). Príklady pohybových hier pre detské kategórie vo futbale(1. až 4 časť). URL: [http://www.trenink.com/index.php?option=com\\_content&task=view&id=1310&Itemid=136](http://www.trenink.com/index.php?option=com_content&task=view&id=1310&Itemid=136)

Nemec, Nemcová, 2012 – Nemec, M., Nemcová, L. (2012). Športové hry a voľný čas detí staršieho školského veku. *Exercitatio corporis – motus – salus*, vol. 4, r. 2, pp. 139-146.

Roučková, Argajová, 2013 – Roučková, M., Argajová, J. (2013). Netradičné pohybové hry. Bratislava: Metodické centrum Bratislava, 58 p.

Skružný et al., 2015 – Skružný, Z. et al. (2015). Florbal. První vydání. Praha: Grada, 120 p.

Slezák, Melicher, 2008 – Slezák, J., Melicher, A. (2008). Analýza záujmovej telesnej výchovy v súčasných podmienkach In *Telesná výchova a šport, zdravie a pohyb*. Prešov: MPC Bratislava, alokované pracovisko Prešov, pp. 46-56.

Verešová, 2004 – Verešová, M. (2004). Mediátory užívania drog. Cesta k efektívnej prevencii drogových závislostí. Nitra: Fakulta sociálnych vied a zdravotníctva UKF, 388 p.

Copyright © 2018 by Academic Publishing House Researcher s.r.o.



Published in the Slovak Republic  
European Journal of Physical Education and Sport  
Has been issued since 2013.  
E-ISSN: 2409-1952  
2018, 6(2): 50-54

DOI: 10.13187/ejpe.2018.2.50  
[www.ejournal7.com](http://www.ejournal7.com)

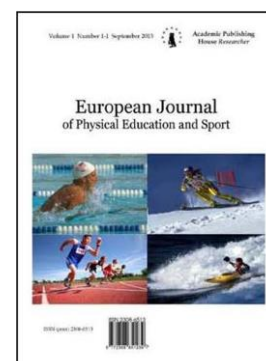

## The Impact of Physical Programs to the Level of Muscle Imbalance in Pupils of the 8<sup>th</sup> Grade at Primary School

Marian Knechta <sup>a, \*</sup>

<sup>a</sup> Faculty of Arts, Matej Bel University, Slovakia

### Abstract

The aim of this study was to find out the impact of the physical program focused on the level of muscle imbalance in boys of the 8th grade at primary school Pri kríži 11 in Bratislava, implemented at physical and sports educational classes. Average age, high and weight of subjects =13.93 years, 163 cm and 52.6 kg. The muscle diagnosis with a tendency towards shortening and weakening was carried out by examination manoeuvres according to Labudová, Thurzová 1992. Diagnosis: 11 muscles shortened, and 5 muscles weakened. The SPSS 17.0 statistical system was used to process statistical data, where the statistical significance of differences was determined by using a non-parametric WILCOXON test at 5 % level of statistical significance  $p < 0.05$ .

**Keywords:** muscle imbalance, physical program, shortened muscles, weakened muscles.

### 1 Introduction

The issue of muscle imbalance is currently a growing global problem, which needs to have an increased attention. As many studies have proved, a high incidence of muscle imbalance has already been shown in pupils at the young-school-age and is related to incorrect body holding. Several authors have been dealing with the issue of muscle imbalance such as Labudová, Thurzová (1992), Kováčová (2003), Kanasová (2004), Nelson (2004), Zachrla (2004), Bursová (2005), Straková (2006), Rodriguez (2008), Jurašková, Bartík (2010), Marshall (2011), and many others.

Kováčová (2003) states the 100 % occurrence of muscle imbalance in boys at the second grade of primary schools. Kanasová (2004) recorded the 100 % occurrence of muscle imbalance in 10-12 years old pupils. Bendíkova, Stacho (2011) found out, that boys on the second grade at primary school in Poniky had a 92.59 % occurrence of shortened muscles.

Kanasová (2014) states, that the functional relationship between postural and phasic muscles is more important than the quality of an individual muscle in which the damage can cause a muscle imbalance. Therefore, it is essential to recognize, that a muscle imbalance is the first stage of other more serious functional disorders of the supporting and musculoskeletal system. Muscle imbalance is a significant functional disorder, resulting in incorrect body holding, damage of movement stereotypes and limited joint mobility, which are unevenly weighted. These problems are often associated with pain and limit people in working or doing sports.

For the reasons mentioned above, people should exercise their muscle groups from the early ages and of course teachers at maternity wards and elementary schools should help them with it at physical education classes as well.

\* Corresponding author

E-mail addresses: [pavol.bartik@umb.sk](mailto:pavol.bartik@umb.sk) (M. Knechta)

**The aim of the study:**

The aim of the rigorous thesis was to find out the impact of 3 months long physical program focused on the level of muscle imbalance in boys of the 8th grade at primary school Pri kríži 11 in Bratislava, implemented at physical and sports educational classes.

**Hypotheses:**

Hypotheses have been developed on the basis of a number of studies on muscle disbalance and their results.

**H1:** It is assumed, that the muscle imbalance will be shown in more than 50 % of subjects.

**H2:** It is assumed, that the impact of physical program will cause a statistically significant improvement of muscle imbalance in more than 50 % of muscle groups tested.

**H3:** It is assumed, that after the completion of the physical program, the greater statistical significance of the differences will be demonstrated between input and output measurements in weakened muscle groups as well as in shortened muscle groups.

**2. Materials and methods**

The research was implemented over the following 4 months: September - December 2017. Input measurements took place on September 7, 2017 and September 12, 2017 in the gym at primary school Pri kríži 11 in Bratislava under the leadership of Mgr. M.L., Mgr. M.K. and Mgr. K.M. during physical education classes and breaks, based on the model of Labudová, Thurzová (1992) modified for the purposes of health physical education. Subsequently, pupils split up to half, 13 pupils into two groups: experimental and control. The experimental group attended between September 14, 2017 and December 14, 2017 a 3-month (13-week) physical program focused on the relaxation and stretching of shortened muscle groups followed by activation and strengthening of weakened muscles in pupils of the 8th grade. The program took place twice a week during first 30 minutes of physical education classes, always on Tuesdays at 5th class from 11:55 to 12:40 and on Thursdays at 3rd class from 9:55 to 10:40, with the exception on October 31, 2017 (fall break). At the same time, the control group attended the regular physical education classes. Output measurements took place in the gym at primary school Pri kríži 11 in Bratislava on December 19, 2017 and December 21, 2017 during the physical education classes and breaks under the leadership of Mgr. M.L., Mgr. M.K., a Mgr. K.M.

The qualitative methods of comparison, analysis, synthesis, induction and deduction were applied in the processing and evaluation of acquired research facts. From quantitative methods, the basic statistical characteristics were used such as arithmetic average, standard deviation, median, maximum and minimum. The SPSS 17.0 statistical system was used to process statistical data, where the statistical significance of differences was determined by using a non-parametric WILCOXON test at 5 % level of statistical significance  $p < 0.05$  (Chráska, 2007).

**3 Results**

**H1:** Hypothesis one was confirmed because 100% of the probands in the intake measurements had muscle disbalance.

**H2:** Hypothesis two was confirmed because in the experimental group there was an improvement in all probands.

**H3:** Hypothesis three has also been confirmed because greater statistical significance has been demonstrated in weakened muscle groups.

**Table 1.** The results of the shortened and weakened muscles of the experimental group

	m. triceps surae	m. iliopsoas	m. rectus femoris	m. tensor fasciae latae	knee joint flexors	adductores coxae	m. quadratus lumborum	m. erector spinae	m. pectoralis major	m. trapezius, pars superior	m. levator scapulae	m. gluteus maximus	adductors of the hip joint	m. abdominis	Deep neck and head flexors	shoulder blade fixators (lower)
input	3,85	7,69	1,54	3,85	0,77	8,46	8,46	1,53	6,13	4,62	8,46	9,23	3,85	9,26	9,23	1,54
output	0,77	8,46	8,46	6,92	6,15	5,38	5,38	0,77	3,08		5,38	3,07	3,07	,69	6,15	4,62
	,083	,059	,063	,038	,034	,083	,063	,046	,038	,014	,014	,014	,038	,005	,083	,020

**Table 2.** Results of the shortened and weakened muscles of the control group

	m. triceps surae	m. iliopsoas	m. rectus femoris	m. tensor fasciae latae	knee joint flexors	adductores coxae	m. quadratus lumborum	m. erector spinae	m. pectoralis major	m. trapezius, pars superior	m. levator scapulae	m. gluteus maximus	adductors of the hip joint	m. abdominis	Deep neck and head flexors	shoulder blade fixators (lower)
input	6,92	5,38	1,54	3,85	5,38	3,85	0	3,84	6,13	6,15	6,15	1,54	2,31	1,54	9,23	7,69
output	4,62	1,54	1,54	6,15	5,38	3,85	3,85	8,46	9,23	6,15	0	3,85	8,46	6,15	3,85	6,15
	,102	,655		,414			,655	,157	,083		,317	,564	,317	,157	,157	,083

#### 4. Discussion

In our research at the Secondary Primary School Pri Kríži 11 Bratislava, we recorded a 100% incidence of muscle imbalance in 8th grade pupils (boys). It should be noted, that we need only one shortened or weekend muscle to talk about muscle imbalance. All of the 16 tested muscles in the experimental group had an improvement. A statistically significant improvement to 5 % of the level of statistical significance occurred with up to 6 shortened and 4 weekend muscles. In the control group, we did not record statistically significant improvement. However, we found out that by classical physical education lessons there was an improvement in 8 muscles, stagnation in 3 muscles and deterioration in up to 5 muscles.

Rodriguez (2007) says that in his experiment with the experimental group, there were positive changes after the stretching program, but in the control group there was a deterioration in some cases. In our experiment, we experienced similar positive results in the experimental group and worsening in 5 muscles in the control group.

In the experimental group, the best progression of the shortened muscles was achieved in the m. levator scapulae and m. trapezius, pars superior, where  $P = 0.014$  was 5 % of the statistical significance. A statistically significant difference to 5 % of the statistical significance level was also demonstrated in the knee flexors  $P = 0.034$ , the m. pectoralis major and the m. tensor fasciae latae  $P = 0.038$  and also in the m. erector spinae  $P = 0.046$ . For the rest of the muscles (m. iliopsoas, m. rectus femoris, m. quadratus lumborum, m. triceps surae, adductores coxae) was improved by 3 month training program, but statistical significance at 5 % level of statistical significance was not demonstrated.



The largest incidence (80.77 %) of shortened muscles was recorded in the flexor of the knee joint where, after completing the three month training program, we recorded a statistically significant difference to 5 % of the statistical significance level  $P = 0.034$ . The result coincides with the experiment Jurašková-Bartík (2010), where they recorded the greatest 75 % incidence of shortened muscles in the flexor of the knee joint, and also from Thurzová (1991), where the greatest incidence of shortened muscles in the flexor of the knee joint was 65.5 %.

For the weakened muscles, we recorded a statistically significant difference in the experimental group to 5 % of the level of statistical significance in 4 of the 5 muscle groups tested. The best progress was recorded in m. abdominis where the statistical significance at 5 % level of statistical significance was  $P = 0.005$ . Statistical significance at 5 % of the statistical significance level was also demonstrated in the m. gluteus maximus  $P = 0.014$ , lower blade fixators  $P = 0.020$  and in hip abductors  $P = 0.038$ . With deep neck and head flexors, there was also improvement, but statistical significance at 5 % level of statistical significance was not demonstrated.

## 5. Conclusion

The results show, that a three-month physical program to eliminate muscle imbalance at the second grade at primary schools is a very effective way to prevent or eliminate muscle imbalance in pupils. In the experimental group, all muscles improved, while in the control group, due to classical physical education classes there was an improvement within 8 muscles, stagnation within 3 muscles and a deterioration within 5 muscles. Significant improvements were observed in weakened muscles, where we reached 5 % level of statistical significance with 4 muscle groups. Therefore we recommend studying muscle imbalance and physical programs focused on elimination muscle imbalance. We also recommend doing examinations focused on muscle imbalance at the beginning of the school year. According to the results, physical education teachers should use more compensatory exercises at physical and sports educational classes, and encourage pupils to exercise with a proper technique.

## References

- Bakytova et al., 1975 – Bakytova, H., Ugron, M., Kontseková, O. (1975). Základy štatistiky. Vyd. Bratislava: Alfa, 258 p.
- Bartosik, 1994 – Bartosik, J. a kol. (1994). Teória a didaktika zdravotnej a nápravnej telesnej výchovy. Vyd. Nitra: PF.
- Bendikova, 2011 – Bendikova, E. (2011). Oporný a pohybový systém, jeho funkcia, diagnostika a prevencia porúch. 132 p.
- Bendikova, 2012 – Bendikova, E. (2012). Oslabený oporný a pohybový systém žien a jeho úprava pohybovým programom. Vyd. Banská Bystrica: Univerzita Mateja Bela 2012. 98 p.
- Bursova, 2005 – Bursova, M. (2005). Kompenzační cvičení. Vyd. Praha: Garda Publishing, 196 p.
- Juraskova, Bartik, 2010 – Juraskova, Ž., Bartik, P. (2010). Vplyv pohybového programu na držanie tela a svalovú nerovnováhu žiakov 1.stupňa základnej školy. Vyd. Banská Bystrica: Fakulta humanitných vied UMB. Prvé vydanie. 172 p.
- Chrastka, 2007 – Chrastka, M. (2007). Metody pedagogického výzkumu. Vyd. Praha: Grada Publishing, 116 p.
- Janda et. al., 2016 – Janda, V. et. al. (2016). Svalové funkční testy. Vyd. Praha: Grada Publishing, 325 p.
- Kampmiller et. al., 2010 – Kampmiller, T. et. al. (2010). Základy metodológie výskumu v telesnej výchove a športe. Vyd. Bratislava: ICM agency, 193 p.
- Kanasova, 2004 – Kanasova, J. (2004). Funkčné svalové poruchy u atlétov, tenistov, plavcov, hokejistov, volejbalistiek a moderných gymnastiek OŠG v Nitre. Praha: KA FTVS UK.IN Atletika: elektronický zborník medzinárodnej vedeckej konferencie, 17 p.
- Labudova, Thurzova, 1992 – Labudova, J., Thurzova, E. (1992). Teória a didaktika zdravotnej telesnej výchovy (vybrané kapitoly). Vyd. Bratislava: Univerzita Komenského v Bratislave, 102 p.



[Marshall et. al., 2011](#) – *Marshall, P. et. al.* (2011). A randomized controlled trial for the effect of passive stretching on measures of hamstring extensibility, passive stiffness, strength, and stretch tolerance.

[Nelson, Bandy, 2004](#) – *Nelson, T., Bandy, D.* (2004). Eccentric training and static stretching improve hamstring flexibility of high school male.

[Rodriguez, 2008](#) – *Rodriguez, P.L.* (2008). Effect of physical education stretching programme on sit and reach score in schoolchildren.

[Zachrla, 2004](#) – *Zachrla, J.* (2004). Svalová dysbalance u hráčů ledního hokeje. Bratislava: Zborník vedeckých prác Katedry hier FTVŠ UK č.1. 110 p.

Copyright © 2018 by Academic Publishing House Researcher s.r.o.



Published in the Slovak Republic  
European Journal of Physical Education and Sport  
Has been issued since 2013.  
E-ISSN: 2409-1952  
2018, 6(2): 55-60

DOI: 10.13187/ejpe.2018.2.55  
[www.ejournal7.com](http://www.ejournal7.com)

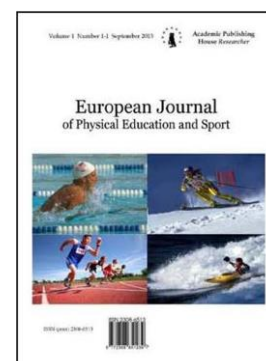

## The Intensification of Speed-Power Ability Control of Basketball Players

Victor Koryahin <sup>a</sup>, Oksana Blavt <sup>a,\*</sup>, Elena Bezgrebelnaya <sup>a</sup>

<sup>a</sup>National University «Lviv Polytechnic», Ukraine

### Abstract

Control, as an organic component of the basketball players training, provides management of this process and is a factor of its effectiveness. When the fact that control of basketball players speed-strength abilities requires absolutely precise and effective methods of their diagnostics was taken into account, it was determined the necessity of effective control techniques search for obtaining reliable information on the state of basketball players speed-strength abilities. To solve those problems we used methods of analysis and synthesis, analogy, abstraction, formalization, technical modeling and mathematical statistics. The main idea of the research was to intensify the control process of the basketball players speed and strength abilities. For this purpose, we propose to apply our device to determine the speed-strength abilities level development. Along with the definition the distances time overcoming, other important characteristic of the basketball players speed-strength abilities are calculated with use of the mathematical statistics methods. Modified control method for the speed-strength abilities of basketball players was proposed for the first time. Its use contributes increasing of the control effectiveness of the basketball players speed and strength abilities by operative and effective analysis and interpretation of quantitative testing information.

**Keywords:** basketball, control, technique, speed-strength abilities, device, effectiveness, statistics, reliability.

### 1. Introduction

The highest achievements of the sport progress is associated with the justification of the elements of the athletes training system and its orientation on sport results (Colibaba, et al., 1998). The high-class basketball players training is a complex, dynamic pedagogical process based on a deep understanding of the factors that determine its effectiveness under the direct influence of those changes that occur in science (Koryahin, 1998; Simion, et al., 2000). Accordingly, this requires mastering the knowledge of the latest scientific achievements in the training of highly skilled athletes.

The modern level of the basketball development is characterized by a high development level of physical qualities (Koryagin et al., 2016). The leading strategic direction of high qualified basketball players training in modern conditions and an important part of the training process is the control of the level of their physical training (Semashko et al., 1976; Romanenko, 2013). Control, as the organic component of the basketball players training, provides management of the process and is its effective factor (Buceta et al., 2000; Simion et al., 2000).

\* Corresponding author

E-mail addresses: [oksanablavt@ukr.net](mailto:oksanablavt@ukr.net) (O. Blavt), [koryahinv@meta.ua](mailto:koryahinv@meta.ua) (V. Koryahin), [olena.bez@icloud.com](mailto:olena.bez@icloud.com) (E. Bezgrebelnaya)

It is determined in the theory and methodology of sports, that the effective management of the basketball athletes training is the use of means and methods of integrated control (Romanenko, 2005; Koryahin, et al., 2013). Such control is considered to be one of the most important links in the system of training of high qualified athletes. Its expediency is considered from the position of creating the opportunity for the coach to adjust the training process during the period of athletes training for important sports competitions (Raiola et al., 2016).

The practice of modern sports, numerous scientific studies indicate that at the current stage of basketball players training, there is a need to transform the accumulated knowledge and best practices of scientific achievements in the control implementation. In accordance with the requirements of the time, the global development of technology causes the necessity of significant changes in the organization of control in basketball.

The relevance and timeliness of study of the control techniques in basketball is determined by the fact that the search and introduction of scientific achievements in this process, promotes significant improvement in the quality of control procedures and gained the results. We see the importance of the latest research methods of organizing control in basketball because of the growing demands that modern training process puts forward. The growing level of sports results requires new tools and methods for the perfection and improvement of the training process.

## 2. Reviews of related literature

The research analysis of this problem shows that it constantly attracts the attention of sports professionals (Bompa, 2002; Colibaba et al., 1998; Makarov, 2013). In the process of training athletes for competition it is important to monitor its various aspects of this process, including such an important factor as their physical training (Semashko et al., 1976). The last may be considered as a component of the multi-year training of basketball players, the aim of which is the creation of optimal conditions for achieving the highest results at the stage of their sports achievements (Simion et al., 2000).

The questions of optimizing the training process of basketball players are considered (Colibaba et al., 1998; Koryahin, 1998; Losin et al., 2011; Poplavsky, 2004; Semashko et al., 1976; Verkhoshanskiy, 1985). Speed-strength training is crucial among the many factors that make possible the achievement of the high sports results. Speed-strength abilities (Afonshin et al., 2016; Matiegka, 1991) are considered to be one of the most important qualities of a basketball player: the effectiveness of game activity of players mostly depends on the speed of simple and complex motor reactions, the speed of movement when performing gaming techniques, the maximum speed of movement. The particular importance in the training process is not only the technique of speed training, including special, but also a technique for determining the level of development of this quality. Taking into consideration the fact that the level of development of speed and strength abilities of basketball players limits the effectiveness of the team's competitive activity as a whole, a significant list of research works are devoted to the problems of qualitative control on the level of the development of these abilities (Koryahin et al., 2013; Romanenko, 2013; Zaporozhanov, 1988). Recently, the relevance of such work has increased because of those high requirements for the level of physical abilities of athletes, which are put forward by modern training process in basketball.

It is established that the control of the level of development of speed-strength abilities is realized by different methods, one of which determines the maximum speed of overcoming the distance (Zaporozhanov, 1988). For a long time, in basketball was used a simple procedure for determining of the level of development of speed – with the help of a stopwatch. The possibility of an error in setting the exercise time, which was recorded by a stopwatch, practically excluded the reliability of the results control. There is also a certain dependence between the subjective assessment of the perception of the specialist that makes this assessment and the observance of the necessary requirements of the provided tests, which are set visually. Consequently, the main disadvantage of this method of control is the accuracy of measurement, which is practically impossible to provide.

The method proposed by I.V. Vsevolodov (1969) became the significant progress in the direction of improvement of the methodology for determining the speed. The method supposed the usage of the registration equipment – a "photo terminal" (Koryahin et al., 2013). Such an invention made it possible to record a number of indicators that fully characterize the level of development of the athlete's speed and their strength abilities.

Speed-strength abilities can be seen in the possibility to perform movement in the shortest possible time in the case of active opposition to this movement (Semashko et al., 1976). With the use of photo finish installation, the speed of the starting acceleration, the maximum running speed over the distance, the starting force, the "explosive" strength of the legs and the whole body are monitored. Thus, you can determine the time of the distance of 20, 30, 40 or 100 m the athlete passes with the maximum speed (Koryahin et al., 2013).

Taking into account the fact that the control of the speed and strength abilities of basketball players requires an absolutely accurate and effective methodology for determining its development, it has been found that it is necessary to search for effective ways of improvement of the objectivity of control techniques and for the obtaining of the reliable information about the state of the speed and strength abilities of basketball players.

### **3. Methods and organization of the research**

The purpose of the research is to develop a technique for controlling the speed and strength abilities of basketball players.

Methods of research: methods of analysis and synthesis, analogy, abstraction, formalization, technical modeling and mathematical statistics were used to solve posed problems.

### **4. Results and discussion**

The main idea of our research is to intensify the controlling process of the speed-strength abilities of basketball players. For this, first of all, we apply the device developed by us to control the level of development of speed-strength abilities. The device consists of starting blocks and three installations. The capacitive motion sensors are placed on the starting blocks and installations, which are able to record and promptly transfer information to the electronic computing device while crossing the distance segments by the athlete, with a resolution of 0.001 s. The practical use of the capacitive motion sensors in our device is access to wide range of advantages. In addition to a small and simple design, they are reliable with a long life. High accuracy of work ensures the indispensability of capacitive sensors in devices in which errors are allowed only in hundredths and even thousandths of a percent (Koryahin et al., 2013).

The developed method of the speed-power abilities control is giving the idea of the capacitive motion sensors that are fixed on the athlete, installed on the starting blocks and along the whole course of the distance. The operating principle of the developed device is in the informative signal that arises between the two sensors in the moment, when the distance was passed by the athlete and allows you to record the start time, the time of overcoming of each distance segment and finish. The signal that was received by the sensors is transmitting to the microcontroller, where it is analysed and by wireless technical means of information (Bluetooth) transferring to the electronic recorder (computer).

The use of the developed portable device for speed-power abilities monitoring provides an effective and prompt access to the reliable data at the level of their development in basketball players. Standardization of the testing procedure ensures the reliability of monitoring information the result of which is determined instantly. The device is compact and has a high sensitivity level. The results of multiple tests are displayed automatically on the monitor in the form of an electronic protocol. Thus, the listed factors of the developed device provide realization of an objective, rational, purposeful operational control of the speed and strength abilities of basketball players. The use of the developed control system for the speed and strength abilities of basketball players provides instant diagnostic of the level of their development, which consists of: the time of information obtaining (usually within 20-60 s), the time of the obtained data review and the results analyzing. The proposed automatic system provides recording of numerous control data and storing it on a disk that available for further processing. Use of the proposed device in time of the basketball players speed-strength abilities control process significantly affects the improvement of the process of their physical training. Presentation of the results in the form of an electronic protocol allows us significantly expand and increase the spectrum of representation, facilitates the search and interpretation of the obtained control results, ensures the safety of information and a convenient view of their structure and dynamics. Thus, operational, flowing, step-by-step control and long-term monitoring are performed with updating the results of processing at a given time interval.

Using the obtained control information that based on the dispositions of the combined (complex) approach, we propose, along with the determination of the time to overcome distances, to calculate other important characteristics with a help of the mathematical statistics methods (Mitropolsky, 1961). This is necessary because of the fact that overcoming short distances of 20, 30, 40, 50, 100 m with maximum speed is considered insufficiently informative indicator of the speed-strength abilities level development of basketball players (Matiegka, 1991; Poplavsky, 2004). We cannot characterize the development level of these abilities without the determination of such specific features as the speed of the starting acceleration (Ks), the maximum running speed at the distance (Vm) and the starting force (F). The exponential nature of the correlation between speed and time in such exercises makes it possible to find a mathematical evaluation of these indicators. So, to calculate the starting acceleration (Kc) we use the exponential formula:

$$K_c = \frac{\lg y_1 - \lg y_2}{t_1 - t_2} \times 2,3$$

where: y1 and y2 – increase in speed, in accordance, from 3 (for example) to 6-8 m and from 6-8 m to 20-30 m, it depends on the length of the selected distance;  
t1 and t2 – time to overcome the corresponding distance segments.

To calculate the maximum running speed over a distance (Vm), the following equation is proposed:

$$V_M = \frac{V_t}{1 - e^{-kt}}$$

where: Vt is the speed reached by the time t;  
k – is the rate constant that characterize the initial acceleration;  
e – is the base of the natural logarithms.

To determine the starting force (F), the following formula is recommended:

$$F = \frac{P}{g} \times K_c \times V_M \times e^{-kt}$$

where: P – weight of the athlete;  
g – the acceleration due to gravity.

Received with the use of such mathematical calculations information makes it possible to carry out a differentiated and objective assessment of the speed-strength capabilities of athletes. The processing of a significant array of control results with their restoration and adjustment, as well as their accumulation, takes place in an integrated database. In such a base, replication and interactive analysis of control results are established.

For the first time it is proposed technique for the basketball players speed and strength abilities control, which use portable device that based on modern technologies and computational mathematical statistic methods that ensures the intensification of the test process. Its practical use makes it possible to characterize basketball players speed-strength abilities with far more greater accuracy. Thus, we may see the improvement of the monitoring process effectiveness by operative analysis and interpretation of quantitative testing information.



The introduction of the proposed speed and strength abilities control technique for the process of basketball players' physical training makes it possible to unify and speed up the receiving and processing of control results. Consequently, the effectiveness of management of this process is increased on the basis of prompt correction of individual pedagogical influences.

## 5. Conclusion

The research material that was presented offers a new qualitative approach to the process of monitoring and assessing the level of basketball players speed-strength abilities development with use of technical control means, as well as additional parameters that characterize the speed-power capabilities. The main indicators of the effective using the developed automated system in the process of basketball players speed and strength abilities control are: convenience in use and compactness of the device, comfortable testing, short testing time, high sensitivity of the device and its multi-functionality. The main methodological result of the work is that the use of the proposed technique for basketball players speed and strength abilities control allows to intensify the testing process during their physical training. That allows you to reasonably draw conclusions about the need for adjustments in the program of classes in accordance with the results.

## References

- Allawi, 1992 – Allawi Mohamed Hossam (1992). The science of sports training. Cairo: Knowledge house, 412 p.
- Afonshin et al., 2016 – Afonshin V.E., Rozhentsov V.V. (2016). The Method of Team Sports Athletes' Motor Skills Development. *European Journal of Physical Education and Sport*, 12(2): 34–40. DOI: 10.13187/ejpe.2016.12.34
- Bompa, 2002 – Bompa T.O. (2002). Periodizacao teoria e metodologia do treinamento. San Paulo: Phorte Editora Ltd., 424 p.
- Buceta et al., 2000. – Buceta J.M., Mondoni M., Avakumovic A., Killik L. (2000). Basketball for Young players. Guidelines for coaches. Madrid: FIBA, 358 p.
- Colibaba et al., 1998 – Colibaba E.D., Bota I. (1998). Sports Games, Theory and Methodology. Bucharest: Publishing House Aldin, 470 p.
- Koryahin et al., 2013 – Koryahin V., Blavt O. (2013). Test control in physical education: monograph. Germany: LAP LAMBERT Academic Publishing is a trademark of: OmniScriptum GmbH & Co. KG, 144 p.
- Koryahin, 1998 – Koryahin V.M. (1998). Training of highly skilled basketball players. Lviv: "The Edge", 191 p.
- Koryahin, et al., 2016 – Koryahin V., Blavt O., Grebinca G. (2016). Optimization of the technical training system. *Journal of Physical Education and Sport*, 16(2), 163: 1029–1030.
- Losin, et al., 2011 – Losin B.E, Makarov Yu.M. (2011). Structuring the pedagogical basis for the training of sportsmen igrovikov based on the system approach. *Uchenye zapiski universiteta im. P.F. Lesgaft*, 8: 115–120.
- Makarov, 2013 – Makarov Yu.M. (2013). The concept of formation of game activity in sports games. *Uchenye zapiski universiteta im. P.F. Lesgaft*, 7: 78–83.
- Matiegka, 1991 – Matiegka J. (1991). The testing of physical efficiency. *Amer. Journal of Physical Anthropology*, 4(3): 125-134.
- Mitropolsky, 1961 – Mitropolsky A.K. (1961). Technique of statistical calculations. Moscow: Physics and Mathematics Lyceum, 212 p.
- Poplavsky, 2004 – Poplavsky L.Y. (2004). Basketball. Kiev, publishing house "Olympic Literature", 446 p.
- Raiola et al. 2016 – Raiola Gaetano, Altavilla Gaetano, Tafuri Domenico, Lipoma Mario (2016). Analysis of learning a basketball shot. *Journal of Physical Education and Sport*, 16(1), 1: 3–7. DOI:10.7752/jpes.2016.01001
- Romanenko, 2005 – Romanenko V.A. (2005). Diagnosis of motor abilities. Donetsk: Publishing house. 290 p.
- Romanenko, 2013 – Romanenko V.A. (2013). Diagnosis of motor abilities: monograph. Germany: LAP LAMBERT Academic Publishing is a trademark of: OmniScriptum GmbH & Co. KG, 289 p.

[Semashko et al., 1976](#) – Basketball. Under. Ed. Semashko N.V. (1976). Moscow: Physical Culture and Sport. 264 p.

[Semenov, 2011](#) – *Semenov L.A* (2011). Introduction to research activities in the field of physical culture and sports. Textbook: uchebnoe posobyje. Moscow: Sovetskyi sport, 200 p.

[Simion et al., 2000](#) – *Simion Gh., Mihaila I., Stanculescu G.* (2011). Sports training, systemic concept. Ed. University Press, Constanta, 290 p.

[Verkhoshanskiy, 1985](#) – *Verkhoshanskiy Yu.V.* (1985). Programming and training process organization. *Physical culture and sport*, 5: 26–83.

[Zaporozhanov, 1988](#) – *Zaporozhanov V.A.* (1988). Sports training control. Kiev: Zdorovja, 205 p.

Copyright © 2018 by Academic Publishing House Researcher s.r.o.



Published in the Slovak Republic  
European Journal of Physical Education and Sport  
Has been issued since 2013.  
E-ISSN: 2409-1952  
2018, 6(2): 61-67

DOI: 10.13187/ejpe.2018.2.61  
[www.ejournal7.com](http://www.ejournal7.com)

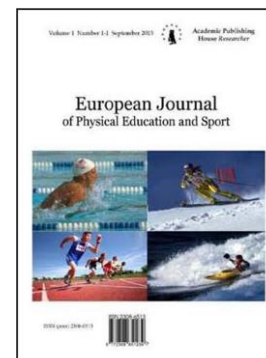

## Level of Students' Posture in Adolescence in Relation to Physical Activity

Michal Marko <sup>a</sup>, Robert Rozim <sup>a</sup>, Perta Kurková <sup>b</sup>, Elena Bendíková <sup>a, \*</sup>

<sup>a</sup> Matej Bel University, Slovakia

<sup>b</sup> Palacký University Olomouc, Czech Republic

### Abstract

The aim of the partial task of the research has focused on the level of the students' posture in the adolescence in relation to the physical activity, as well as the relationship between the mentioned factors. The monitored group consisted of 186 high school students of Žilina region, of which were 92 boys and 94 girls who were the students of the 3<sup>rd</sup> and 4<sup>th</sup> grades. The partial part of the research was realized in three consecutive stages in October and November of the school year 2017/2018. The mean age of the boys was 17.9±0.9 years old and the girls was 18.2±1.3 years old. From the point of view of the data acquisition methods, we used the standardized method of the evaluation of the posture, common for the physical education practice. From the point of view of the information acquisition about the physical activity, we used the interrogative method, the questionnaire. The results provide the primary information about the state of the muscular and skeletal system of the students in the adolescence with the intention to the posture. The incorrect posture was found in girls ( $\chi^2 = 7.119$ ), as well as in boys ( $\chi^2 = 6.926$ ), which was marked by the III. qualitative degree of the posture evaluation. What is more, the highest incidence of the kyphotic posture was proven in boys (32 %,  $\chi^2 = 7.311$ ;  $p < 0.01$ ), while the scoliotic posture was proven in girls (38 %,  $\chi^2 = 6.982$ ;  $p < 0.01$ ) with the significant difference. The results, at the same time, significantly ( $p < 0.01$ ) point to the receptive way of the leisure time for the high school students. The partial monitoring of the research shows the relationship between the monitored factors in girls ( $r = 8.993$ ), as well as in boys ( $r = 7.321$ ). *This article is a part of the grant task: VEGA No. 1/0242/17 Physical activity as prevention of functional disorders related to the musculoskeletal system of secondary school students.*

**Keywords:** posture, physical activity, pupil.

### 1. Introduction

Civilization diseases, specifically an obesity and an especially associated inactivity, a sedentary lifestyle, deformations, as well as functional and structural disorders in relation to a correct posture have become serious public health problems of a present time, not excluding Slovakia (Kanášová, 2004; Kratěnová et al., 2005; Salminen et al., 2007; Majerík, 2009; Bendíková, Stacho, 2010; Adamčák, et al., 2011; Kanášová, Šimončíčová, 2011; Farioli et al., 2014; Azabagic et al., 2016; Bendíková, 2016; Ludwig et al., 2016; Noll et al., 2016), in which more than three quarters of patients complained about a pain in a spine (Jonsson et al., 1999; Mackenzie et al., 2003), while in Europe a prevalence was up to 22 % (Eurobarometer, 2007). The pain in

\* Corresponding author

E-mail addresses: [elena.bendikova@umb.sk](mailto:elena.bendikova@umb.sk) (E. Bendíková)



children, at least 1 time in life, was recorded in 46 % – 53 %, while the persistent pain was up to 15 %. Similarly, the situation has worsened in Slovakia and other countries, as for example the situation from 1996 to 2008 had tripled.

Health insurance statistics have showed that the situation of a muscular and a skeletal system has been a social and an economic problem, not only in the Member States of the European Union, but also in the United States of America, where roughly one seventh of patients may receive an adequate health care, as every year \$ 250 billion have been invested into the health care (Stellman, 1998; Mathers, Penm, 1999; DeFranco et al., 2009). Similarly, in Australia, total expenditure, in 1993/1994 climbed up to \$ 3002 million and in the Nordic countries (Denmark, Sweden, Norway, Finland and Iceland) was estimated to 2.7 % – 5.2 % of gross domestic product, which was invested in a treatment of the muscular and skeletal system.

An external manifestation of the functional disorders in the area of the muscular and skeletal system is the posture, which results in a certain shape and a function of the spine. It is an accompanying sign of every activity, as well as it is itself an act, a physical habit that can be managed by owns' will (Čermák et al., 2005).

The correct posture is defined more economically than aesthetically, as according to Buran (2002) represents a vector's optimally centered knee position with minimal demands on a muscular activity of the posture. Kolář et al. (2009) view the posture as a sign of a human being or a particular way of realizing a postural stereotype, while Bendíková (2011) mentions that the posture is the position of individual segments in a time and a space, which is the external manifestation of the muscular system. The opposite of the correct posture is an incorrect posture, which has its features manifested in typical functional disorders of the posture (Čermák et al., 2005). Labudová, Vajcziková (2009) perceive the posture as a violation of the habit of the correct posture, in which are presented various variations of a temporary nature (if they are of a permanent nature, they are deformations in the area of the structure of the spine, joints, muscles and ligaments), which interfere an optimal vertical axis of a body. The incorrect posture cannot be compensated by the so-called a spontaneous movement, therefore the posture left only on a natural development is very unreliable.

Nowadays, we have experienced a decline of an interest in the physical activity, realized within, whether organized or not organized forms, not only in primary school pupils, but in high school students as well. In this context, a phenomenon has appeared in a school physical and sport education in Slovakia, which has had an ascending trend. They are known as not taking exercise students, mainly the girls. A lack of the physical activity (of gym character) in the students' physical regime is manifested, not only in their health, but also in their physical ability, performance and physical literacy (Müller et. al., 2008, 2015; Labudová et al., 2009, 2010; Čechovská, Dobrý, 2010; Dobay, 2007; Ihász, Rikk, 2007; Chovanová, Majherová, 2011; Labudová et al., 2012; Szököl, 2015, 2016), by which are created disproportions within the physical development. Labudová (2003) states that the primary schools have been attended by 4 % – 6 % of the pupils with the health disorders, while the secondary schools have been attended by more than a half of the students (13 %). After several years Slezák (2004), Šimonek et al. (2005) report a number of the not taking exercise boys is ranging from 27.7 % to 39.6 %, while the number of the not taking exercise girls is ranging from 38.2 % to 48.1 %. It follows that the number of the students who are freed from the physical activity within the physical and sport education, due to the various diseases and disorders of the health are of an ascendant nature. The practice points to the fact that this state is associated with multiple subjective and objective factors.

The aim of the research was to find out the current state of the muscular and skeletal system with the intention to the posture and physical activity of the secondary school students, as well as the relationship between the mentioned factors, in order to spread the knowledge from the mentioned area.

## 2. Methodology

The monitored group consisted of 186 high school students of Žilina region, of which were 92 boys and 94 girls who were the students of the 3rd and 4th grades. The mean age of the boys was 17.9±0.9 years old and the girls was 18.2±1.3 years old. More detailed characteristics of the monitored group is presented in the Table 1.

The partial part of the research was realized in three consecutive stages in October and November of the school year 2017/2018, where an anonymity of respondents was preserved. In order to obtain the data of the physical activity, we used the interrogative method – the questionnaire entitled "Physical Regime and Health", which was based on the research needs, several authors and national reports of the nationwide researches.

**Table 1.** Characteristics of the monitored group (n = 186)

Mean values (x)	Boys (n = 92)	Girls (n = 94)
Age (years old)	17.9±0.9 years old	18.2±1.3 years old
Body height (TV/cm)	177.8±6.6 cm	165.65±5.5cm
Body weight (TH/kg)	75.2±6.3 kg	58.3±6.6 kg
BMI (Body Mass Index)	23.61±2.9	21.33±2.6

The evaluation of the posture was performed by using the standardized method of the physical education practice, known as Klein and Thomas modified by Mayer (Bendíková, 2011), which is associated with the visual evaluation of the posture, which is divided into four qualitative levels, while is represented by the following marks, respectively degrees (1- 4), where:

- A. Correct posture – without deviations from the standard,
- B. Good posture – with small deviations from the standard,
- C. Wrong posture – with bigger deviations from the standard,
- D. Incorrect posture – with severe deviations from the standard.

To evaluate the qualitative degrees of the posture, we used the Chi-squared test ( $\chi^2$ ,  $p < 0.05$ ). Similarly, for the evaluation of the significance of the difference of the questionnaire answers we used the Chi-squared test ( $\chi^2$ ,  $p < 0.05$ ). The support was the percentage frequency analysis (%) and arithmetic mean ( $x \pm$ ). The Pearson's correlation coefficient ( $r$ ) was used to evaluate the relationship between selected monitored factors. We also used the methods of the logical analysis and synthesis, using the inductive and deductive techniques, comparisons and generalizations. All data were processed differentially by gender of the respondents in the tables.

### 3. Results

Starting from the partial aim and tasks, we present the part of the results that are subject to further more accurate monitoring and processing. The presented results cannot be generalized, but it is necessary to understand them in the overall context, as an orientation and starting in organizing the leisure time of the secondary school students in relation to their health.

Only 15 % of the girls of the monitored group had the correct posture, 30 % had the good posture and 55 % had the wrong posture. In boys, we found the wrong posture in 39 %, while the good posture was in 42 % and the correct posture was in 19 %. Not even in girls or boys, the incorrect posture was not found, which was positive evaluated, in terms of the health. The significant difference ( $\chi^2 = 6.009$ ,  $p < 0.05$ ) among the both genders was recorded in the III. qualitative degree of the posture (Table 2).

**Table 2.** The evaluation of the posture in students (n = 186)

Level of posture / Points	5 points	6-10 points	11-15 points	16-20 points
I. Correct posture	G 15 % B 19 %	-	-	-
II. Good posture	-	G 30 % B 42 %	-	-
III. Wrong posture	-	-	G 55 %* B 39 %	-
IV. Incorrect posture	-	-	G 0 % B 0 %	-

In the area of the *I. evaluation of the head and neck* was rated 17 % of the girls and 2 % more boys (19 %), whose view lead forward, lower part of a jawbone was pushed. The view forward, however an axis of the neck was slightly inclined forward about 10 degrees, which was manifested in 35 % of the girls and 36 % of the boys. The highest percentage representation was found in both boys (48 %) and girls (45 %) by the degree 3.

In the area of the *II. evaluation of the chest* we had the normal chest that was symmetrical, its axis was vertical, as well as was well arched. Ribs contained with the spine 30 degree angle, were symmetrical while breathing, kyphosis was physiological in 29 % of the girls and 19 % of the boys. The small deviations from the standard during the axis of the chest, inclination about 10 degrees were found in 48 % of the girls and in 59 % of the boys. With the 11 % difference in favor of the girls and mentioned percentages, we found in boys (22 %), as well as in girls (33 %), which was rated by the degree 3, characterized by the flat chest and spine, as was considerably bent, a plummet was triggered from a nape of the neck and the plummet attached to the kyphosis lead out of the head. The severe deviations of the chest shape, which was flat and spine was strongly bent in a full arc were not detected.

In the area of the *III. evaluation of the abdomen and inclination of the pelvis*, we found in girls that by the grade 1 was rated 19 %, 2 - 24 % and 3 - 54 % ( $\chi^2 = 8.696$ ;  $p < 0.01$ ). In boys by the grade 1 was rated 21 %, 2 - 39 % and 4 - 40 %. We did not find the state at the level of the grade 4 in girls or boys.

In the area of the *IV. evaluation of the spine curve*, we found in girls with the grade 1 17 % and in boys 28%. The small deviations from the standard, in terms of plus or minus were found in 37 % of the girls and 35 % of the boys. Clearly rounded and flat spine was found in 35 % of the boys and 48 % of the. The severe deviations from the standard were not found in the monitored group.

In the area of the *V. evaluation of the posture in the frontal plane*, a full symmetry, an equal height of shoulders, relaxed shoulders, shoulders do not stay, their inner axes were parallel were in 17 % of the girls and 21 % of the boys. The small deviations of the standard were found in girls (30 %) and boys (34 %). A sliding of one side, a non-asymmetry of a figure, one shoulder was above were in 53 % of the girls and 45 % of the boys. The considerable removal of blades, non-asymmetry of discontinuity of thoracic diaphragm were not been recorded in our group.

We found, in relation to the posture that the boys had the highest incidence of the kyphotic posture (32 %), while the girls had the scoliotic posture (38 %). Both of these findings were significant ( $\chi^2 = 7.311$ ,  $p < 0.01$ ) and ( $\chi^2 = 6.982$ ,  $p < 0.01$ ). Other functional disorders found in boys were the scoliotic posture (27 %), hyperlordotic posture (19 %) and hypolordotic posture (3 %). In girls, with the lowest percentage representation was also the hypolordotic posture, then hyperlordotic posture (15 %) and kyphotic posture (28 %).

The physical activity is necessary for our health, but it must be adequate and regular. That is why we were interested in the following facts.

The leisure time of the boys is spent mostly by the physical activities, while the girls preferred meeting with their friends. 32.5 % of the boys preferred the sport activities ( $\chi^2 = 7.332$ ,  $p < 0.01$ ). The second most popular activity was playing computer games, which was marked by up to 30.2 % of the boys. In 31.1 % of the girls ( $\chi^2 = 7.001$ ,  $p < 0.01$ ), there was meeting with friends. Only 28 % of the girls rated the movement, so it was their second most popular activity in their leisure time. Only 6.3 % of the boys marked the possibility of others, specifically mentioning activities such as a work, a music, a piano, a learning, a reading or a relaxing. The girls marked the option "other" in 7.3 %. In their answers were predominant mainly the reading, including a painting, the piano, a playing with a dog and the learning.

Regardless of the answer of the first question, whether the students preferred watching television or active physical activity, we asked how many minutes a day they spend using a computer or a television. More than half of the boys, namely 57.5 % used the computer or television for 2 - 3 hours a day ( $\chi^2 = 13.642$ ,  $p < 0.01$ ), a quarter of the boys, 25.3 % rated 1 hour a day. The girls did not meet with such a visible difference. Although, their response 2 - 3 hours a day was up to 43.2 % ( $\chi^2 = 11.419$ ,  $p < 0.01$ ). Another 40.7 %, which was almost the same proportion of the girls rated 1 hour a day.

Since a schedule of the high school students usually differs, according to whether they had a regular school day when a majority spent most of the day at school, respectively preparing for the learning or it was a weekend, respectively holidays. That was why we were interested in whether

sport activities depended on this. So we asked if they had more movement during the weekend than school days, holidays or it did not matter. Up to 39.1 % of the boys ( $\chi^2 = 8.112$ ,  $p < 0.01$ ) said that most movement was going during the holidays. This fact was also reported by 39.8 % of the girls ( $\chi^2 = 8.979$ ,  $p < 0.01$ ). 29.9 % of the boys and 24.6 % of the girls said it did not matter whether they had the holidays or weekend, but that they moved almost the same way in most of their time.

In boys, surprisingly the first place ended with a walking, which was marked by 17.6 % of the boys ( $\chi^2 = 5.987$ ,  $p < 0.05$ ). Somewhat less boys, namely 17.1 % rated a football and 12.3 % a strengthening. In girls, as well as boys, the most commonly performed activity was the walking ( $\chi^2 = 6.144$ ,  $p < 0.05$ ). This option was reported by 19.6 % of the girls, another 10.7 % marked a skating and 10.4 % marked a cycling.

The students completed their answers by specifying the frequency, which was how often they performed the activity. 33.3 % of the boys said they performed the sport activity 2 - 3 time a week, another 31.0 % performed it 4 - 6 times a week and 27.6 % each day. The girls stated 43.2 % ( $p < 0.01$ ) as they performed it 2 - 3 times a week, another 31.4 % each day and 12.7 % 4 - 6 times a week. Instead, they specified the answers by saying how many minutes they performed the physical activities. It was shown that most of the respondents spent 30 - 60 minutes a day by doing the sport activities, specifically 45.8 % of the boys and 39.8 % of the girls ( $p < 0.01$ ). Our findings indicated the relationship between the monitored factors (the posture and physical activity), as in girls ( $r = 8.993$ ), as well as in boys ( $r = 7.321$ ).

We were also interested in the students' own view of, whether they were thinking enough about the physical activities time they were doing. 57.5 % ( $p < 0.01$ ) of the boys thought that they devoted enough time to the movement, 31.0 % believed that they dedicated less than they should. Equally, 5.7 %, which was 5 boys said that they were dedicated to the movement more that it was needed and another 5 thought the opposite, as they dedicated to the movement a lack of time. In the girls 55.9 % ( $p < 0.01$ ) reported that they spent less time than they should. The sufficient time was marked by 33.1 %. 8.5 % of the girls were admitted to the lack of time. The answer "more than necessary" was marked by only 3 girls, which was 2.5 %.

We were surprised by the response of the students when more than half of the boys, namely 55.3 % ( $\chi^2 = 12.963$ ,  $p < 0.01$ ) and more than half of the girls 52.7 % ( $\chi^2 = 11.329$ ,  $p < 0.01$ ) answered "because I love the movement".

We also valued positively the fact that the students were aware of the impact of the movement on their health, as up to 33.0 % of the boys and 39.7 % of the girls marked the answer "for the health". The option "other" was marked by 11.7 % of the boys and 7.6 % by the girls. The boys in their answers gave reasons such as: "it was for me relaxing, relieving the stress, I am with my friends, to look good in the summer, I like to improve and I like the success". The answers of the girls were: "Because of the character, it was the necessity, because I had to go with the dog, it was for me relaxing and fun.

Among the most common reasons for the non-sporting, non-exercise of the various forms of the leisure activities, the students responded that they simply did not want it, they did not have enough time or were causing the health problems. These findings and many reasons, according to the current upward trend of the various health disorders were perceived as irresponsible for their health.

#### 4. Conclusion

The realization of the leisure time was different between the boys and girls, the boys preferred the movement, while the girls were meeting with the friends. Up to 57.5 % of the boys and 43.2 % of the girls were using the computer or television 2 - 3 hours a day. Favorite sport activities of the boys included soccer and in girls it was the skating. The boys felt that they had the sufficient time ( $p < 0.01$ ), in terms of the volume of the sport activities, while the girls were less aware of it ( $p < 0.01$ ). Despite the theoretical popularity of the movement in both sexes, we state that in their lifestyle the receptivity prevails over the activity is necessary for the human health.

The level of the posture and evaluation of the individual segments statistically confirmed that only 15.0 % of the girls and 19.0 % of the boys during the period had not disorders of the posture, while functional disorders of the posture appeared in 55.0 % of the girls and 39.0 % of the boys. From the point of view of the type of the disorders, we found that boys had the highest incidence of the kyphotic posture (32.0 %), while the girls had the scoliotic posture (38.0 %).

The above findings point to the phenomenon associated with the physical inactivity, respectively the sedentary way in the lives of the children and youth, not to mention the period of the adolescence, when it is necessary to monitor the level of the posture of the individual developmental periods and subsequently to shape and influence the physical habits, where the physical activity, namely regular is the basis of the healthy lifestyle and health prevention.

## References

- Adamčák et al., 2011** – Adamčák, Š., Bartík, P., Kozaňáková, A. (2011). Úroveň posturálnych a fázických svalov žiakov na 2.stupni základných škôl. Banská Bystrica : UMB FHV KTVŠ, 173 p.
- Azabagic et al., 2016** – Azabagic, S. et al. (2016). Epidemiology of Musculoskeletal Disorders in Primary School Children in Bosnia and Herzegovina. *Materia Socio-Medica*, 28(3): 164–167.
- Bendíková, Stacho, 2010** – Bendíková, E., Stacho, K. (2010). Vplyv kompenzačných cvičení na rozvoj pohyblivosti chrbtice u žiakov II. stupňa. ZŠ. In *Studia kinantropologica*, 11(1): 35–41.
- Bendíková, 2011** – Bendíková, E. (2011). Oporný a pohybový systém, jeho funkcia, diagnostika a prevencia porúch. Banská Bystrica: Univerzita Mateja Bela v Banskej Bystrici.
- Bendíková, 2016** – Bendíková, E. (2016). Changes in the posture of students due to equipment-aided exercise programs that are applied in physical and sport education. *Journal of Physical Education and Sport*, 16(2): 281–286.
- Buran, 2002** – Buran, I. (2002). Vertebrogénne algické syndrómy. Bratislava : S+S.
- Čechovská, Dobrý, 2010** – Čechovská, I., Dobrý, L. (2010). Význam a miesto pohybové gramotnosti v živote človeka. *TVSM*, 76(3): 2–5.
- Čermák, 2005** – Čermák, J. et al. (2005). Záda mne už nebolí. Praha: Vasut.
- Dobay, 2007** – Dobay, B. (2007). Az óvodai testnevelés alapjai –második bővített kiadás. Dunajská Streda: Valeur, s.r.o.
- Defranco et al., 2009** – Defranco, J. et al. (2009). Musculoskeletal Disease in Children and Teenagers: Addressing and Emerging Epidemic. *The Journal of Musculoskeletal Medicine*, 26(2): 122–131.
- Eurobarometer, 2007** – Eurobarometer. Health in the European Union, 2007. URL:[http://ec.europa.eu/health/phpublication/eb\\_health\\_en.pdf](http://ec.europa.eu/health/phpublication/eb_health_en.pdf)
- Farioli et al., 2014** – Farioli, A. et al. (2014). Musculoskeletal Pain in Europe: The Role of Personal, Occupational and Social Risk Factors. *Scandinavian Journal of Work, Environment and Health*, 40(1): 36–46.
- Chovanová, Majherová, 2011** – Chovanová, E., Majherová, M. (2011). Realizovanie pohybových aktivít 10-12 ročných detí východoslovenského regiónu. *Ošetrovatelstvo – pohyb – zdravie* : zborník vedeckých prác. Trenčín : TUAD v Trenčíne, Fakulta zdravotníctva, pp. 275–281.
- Ihász, Rikk, 2010** – Ihász, F., Rikk, J. (2010). Egészségfejlesztés. Győr : szerzői kiadás.
- Jonsson et al., 1999** – Jonsson, H. et al. (1999). Articular Hypermobility in Icelandic 12 Years Olds. *Rheumatology*, 38(10): 1014–1016.
- Kanásová, 2004** – Kanásová, J. (2004). Funkčné svalové poruchy u 10 – 12 ročných žiakov a ich ovplyvnenie v rámci školskej telesnej výchovy : dizertačná práca. Bratislava: Fakulta telesnej výchovy a športu v Bratislave.
- Kanásová, Šimončíčová, 2011** – Kanásová, J., Šimončíčová, L. (2011). Kompenzačné cvičenia ako prostriedok odstraňovania svalovej nerovnováhy u školskej populácie. Šport a rekreácia 2011, Zborník vedeckých prác. Nitra: UKF PF KTVŠ, pp. 52–57.
- Kolař, 2009** – Kolař, P. et al. (2009). Rehabilitace v klinické praxi. Praha: Galén.
- Kratěnová et al., 2005** – Kratěnová, J. et al. (2005). Rizikové faktory a prevalence vadného držení těla u dětí školního věku. *Praktický lékař*, 85(11): 629–634.
- Labudová, 2003** – Labudová, J. (2003). Analytická štúdia o stave a problémoch zdravotnej telesnej výchovy ako vyučovacieho predmetu. Poznatky z výskumu školskej telesnej výchovy. Bratislava: UK FTVŠ, pp. 17–27.
- Labudová, Vajcziková, 2009** – Labudová, J., Vajcziková, S. (2009). Športová činnosť pri poruchách orgánov opory a pohybu. Bratislava : Slovenský zväz rekreačnej telesnej výchovy a športu.
- Labudová et al., 2009** – Labudová, J., Nemček, D., Kraček, S. (2009). Pohybová koordinácia v každom veku. Bratislava : Slovenský zväz rekreačnej telesnej výchovy a športu.



[Labudová et al., 2010](#) – *Labudová, J., Veselá, O., Gályová, I., Nemček, D., Pčolka, P.* (2010). Edukológia zdravotnej telesnej výchovy a športu postihnutých. Bratislava : Slovenský zväz rekreačnej telesnej výchovy a športu.

[Labudová et al., 2012](#) – *Labudová, J., Nemček, D., Antala, B.* (2012). Pohyb pre zdravie. Bratislava, Slovakia: END.

[Ludwig et al., 2016](#) – *Ludwig, O. et al.* (2016). Age-dependency on Posture Parameters in Children and Adolescents. *Journal of Physical Therapy Science*, 28(5): 1607–1610.

[Mackenzie et al., 2003](#) – *Mackenzie, W.G. et al.* (2003). Backpack in Children. *Clinical Orthopaedics and Related Research*, 409(1): 78–84.

[Majerík, 2009](#) – *Majerík, J.* (2009). Svalová nerovnováha a držanie tela 16 – 17 ročných gymnazistov z hľadiska športovania. *Telesná výchova a šport*, 19(1): 18–25.

[Mathers, Penm, 1999](#) – *Mathers, C., Penm, R.* (1999). Health System Costs of Injury, Poisoning and Musculoskeletal Disorders in Australia 1993-94. Canberra: Australian Institute of Health and Welfare.

[Müller et al., 2008](#) – *Müller, A., Könyves, E., Várhelyi, T., Mondok, A.* (2008). Új utakon a testnevelő tanárképzés Egerben – A sportszakos hallgatók utazási szokásainak, és a sítáborozás kínálati elemeivel való elégedettségének vizsgálata. *Economica*, (1): 85–95.

[Müller et al., 2013](#) – *Müller, A. et al.* (2013). Fitnessz trendek a rekreációban. *Acta Academiae Agriensis. XL.*: 25-35.

[Noll et al., 2016](#) – *Noll, M. et al.* (2016). Back Pain Prevalence and Associated Factors in Children and Adolescents: An Epidemiological Population Study. *Revista de Saúde Pública*, 50(31): 1–10.

[Salminen et al., 2007](#) – *Salminen, J. J. et al.* (2007). Risk Factors for Development of Non-specific Musculoskeletal Pain in Preteens and Early Adolescents: A Prospective 1-year Follow-up Study. *BMC Musculoskeletal Disorders*, 46(8): 1–8.

[Slezák, 2004](#) – *Slezák, J.* (2004). Príčiny absencie necvičiacich žiakov na hodinách telesnej výchovy vo vzorke stredných škôl v Slovenskej republike. *Východiská k tvorbe inovovaných projektov školskej telesnej výchovy*. Bratislava : FTVŠ UK, pp. 54–60.

[Szőköl, 2015](#) – *Szőköl, I.* (2015). Quality management system in educational process. Gómez Chova, L. – López Martínez, I. – Candel Torres, I. (eds.): 8th International Conference of Education, Research and Innovation. Seville (Spain) : IATED Academy, pp. 7282–7285.

[Szőköl, 2016](#) – *Szőköl, I.* (2016). Educational evaluation in contemporary schools. Szeged: Belvedere Meridionale, 159 p.

[Šimonek et al., 2005](#) – *Šimonek, J., Halmová, N., Kanasová, J.* (2005). Príčiny neúčasti žiakov na hodinách telesnej výchovy na II. Stupni ZŠ v nitrianskom regióne. *Súčasný stav školskej telesnej výchovy a jej perspektívy*. Bratislava: ICM AGENCY, pp. 46–51.

[Stellman, 1998](#) – *Stellman, M.J.* (1998). Encyclopaedia of Occupational Health and Safety. Geneva: International Labor Office.

Copyright © 2018 by Academic Publishing House Researcher s.r.o.



Published in the Slovak Republic  
European Journal of Physical Education and Sport  
Has been issued since 2013.  
E-ISSN: 2409-1952  
2018, 6(2): 68-79

DOI: 10.13187/ejpe.2018.2.68  
[www.ejournal7.com](http://www.ejournal7.com)

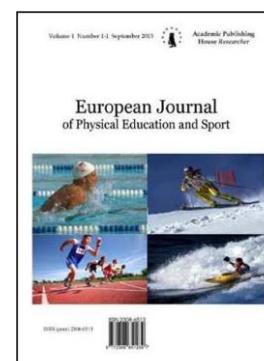

## The Effect of a 10-Week Health Education Program on the Prevention of Injuries in Students With Special Needs

Chrysi Mavrovounioti <sup>a</sup>, Eirini Argiriadou <sup>a,\*</sup>, Argirios Mavrovouniotis <sup>b</sup>, Anastasia Praskidou <sup>c</sup>, Alexandros Kansizoglou <sup>a</sup>, Ioannis Proios <sup>d</sup>, Fotios Mavrovouniotis <sup>a</sup>

<sup>a</sup> School of Physical Education and Sport Science, Aristotle University of Thessaloniki, Greece

<sup>b</sup> Medicine School, Aristotle University of Thessaloniki, Greece

<sup>c</sup> School of Philosophy and Education, Aristotle University of Thessaloniki, Greece

<sup>d</sup> School of Physical Education and Sport Science, Democritus University of Thrace, Greece

### Abstract

The purpose of the present study was to examine the effects of the participation of students with special needs in a health education program for injuries prevention. Ten students of secondary education with mental retardation, aged  $17.63 \pm 2.018$  years, were separated randomly to an intervention group who participated in a 10-week health education program for injuries prevention and a control group who, at the same period, did not attend any extra lesson except the defined ones from the Ministry of Education. Before and after the 10-week period all the students, from both the intervention and the control group, filled in the same questionnaires in order to collect information about their injuries, their experience concerning them, as well their knowledge, attitude and behavior towards injuries. For data analysis, descriptive analysis and the chi square test ( $\chi^2$ ) of the SPSS ver. 17.0 for windows was used. By processing the data, it was shown that the majority of the students (70 %) have an injury experience, either at home (57.1 %) or at school (28.6 %). From the injuries at school, a very significant proportion (38.6 %) occurred during the break, while 32.8 % of the students' injuries occurred in the corridor. In addition, after participating in the 10-week health education program, the students of the intervention group, acquired knowledge regarding possible dangers, understood that they should not run in the school property, that they should not step or run on wet floor, as well as that they should not push others. They also learned how to use electrical appliances and cleaning agents of household equipment properly, and that they should be careful for themselves and for their peers in order to prevent injuries. Likewise, no difference in the control group was observed. Furthermore, the  $\chi^2$  test proved a very significant effect of the students' participation in the health education program regarding injuries' prevention, the knowledge and the right attitude and behavior towards it (Pearson  $\chi^2 = 4.286-6.667$ ,  $p < 0.05$ , Cramer's  $V = 0.655-0.816$ ). Consequently, the implementation of health education programs for the prevention of injuries at students of secondary education with special needs is very important because through them students perceive possible risks and how they should act and behave in certain situations in order not to expose themselves and others to dangers and also prevent injuries.

**Keywords:** mental retardation, disabilities, intervention, attitude, accident, school, home environment, secondary education.

\* Corresponding author

E-mail addresses: [mavrov@phed.auth.gr](mailto:mavrov@phed.auth.gr) (E.A. Argiriadou)

## 1. Introduction

Injuries are a combination of many factors and often have their causes in social differences, social conditions, social behaviours and quality of life in the living space (Papadopoulos, 2005). Injuries are constantly the leading cause of mortality in people aged 1-24 years of both sexes (Kendrick et al., 2013; UNICEF, 2013; WHO, 2008). More specifically, it is the leading cause of infant mortality and the second cause of childhood morbidity and visits to the doctor after the acute infections (Towner, 1994).

As for people with disabilities, they have higher rates of injuries than those without disabilities (Leland et al., 1994). A research conducted in Australia showed that the rate of injuries was higher in individuals with mental retardation in relation to the normal population (Sherrard et al., 2002), as mental retardation affects the expected behavioural, social and functional ability of children (Burkett, 1989). Compared with peers without disabilities, children with disabilities are at a significantly higher risk of injury (Shi et al., 2015).

Of all the groups of people with disabilities, the people with multiple disabilities seem to be the most disadvantaged and have the greatest risk of injury (Valletutti, 1984). Also, blind people seem to have increased risks of accidents on the road, while those with sensorimotor disabilities have increased risks of burns. Similarly, students with orthopaedic disabilities have difficulty controlling their limbs concerning balance and falls. Furthermore, there is a high risk of injury among people with behavioural problems (Sherrard et al., 2002). Conversely, students with developmental disabilities have limited mobility and little contact with their peers, and therefore are less involved in school activities, resulting in a reduced risk of injury (Ramirez et al., 2004).

The legislation of all the developed countries provide for the education of people with disabilities (Ramirez et al., 2004). Since about six million students with disabilities participate in school (Snyder, Hoffman, 2001), the creation of a safe and accessible school environment with appropriate school facilities is essential (Ramirez et al., 2004). It is worth to be mentioned that language-communication, as well as the limitation of cognitive and motor skills may be potential risk factors which can cause injuries at school (Gaebler-Spira, Thornton, 2002).

Regarding the school injuries of students with disabilities, there are not sufficient researches to study them further. However, according to the National Pediatric Trauma Registry, young people with disabilities in school population in the United States account for 17 % of the injuries related to the school but are presented in less than 2 % in the general school population (Snyder, Hoffman, 2001). It has also been recorded high injury rate in special classes with students with developmental disabilities in Switzerland (Woringer, 1995). Accordingly, students with special educational needs in African schools have higher injury rates of teeth than the normal population of students (Ohito et al., 1992).

It is worth to be mentioned that injury prevention rather than overprotection in this special population is important (Kendrick et al., 2013; UNICEF, 2013). However, the successful strategies for preventing children's injuries require a better understanding of the epidemiology of injuries (Zamani et al., 2007). Such knowledge can be acquired through specific educational programs. According to Simpson and Nicholls (2012), future research on injuries in children with disabilities should focus on passive interventions to prevent both intentional and unintentional injuries. In addition, according to Shi et al. (2015) teens with disabilities may be an important subgroup for future injury prevention efforts.

For these reasons, the purpose of the present study is to examine the effects of the participation of students of secondary education with special needs in a 10-week health education program for the prevention of injuries.

## 2. Methods

### Sample

The subjects of the sample were pupils of secondary education attending Laboratories for Special Vocational Education and Training, a structure of education for pupils with special needs in Greece. Of all the pupils of the school, the more functional children were selected in order to participate in the program. More specifically, the sample consisted of 10 students, eight boys and two girls, aged  $17.63 \pm 2.018$  years. The subjects were divided, randomly, into two groups, an intervention group (three boys and two girls) and a control group (5 boys). It is worth to be mentioned that the sample was homogeneous as for the students' level of functionality.



### Experimental Design

The design of this interventional-educational program intended to prevent injuries by changing the attitude and behavior of the subjects of the sample regarding injuries. The implementation of the experimental design was firstly made by the questionnaire method which allowed the collection of information regarding the knowledge, attitude and behavior of the pupils, of both intervention and control group, concerning injuries and their experience of them.

Then followed a 10-week educational program that is 10-hour classes for the students of the intervention group, during which they were able to learn some very important data about injuries, play games, dramatize tales, discuss and draw some symbols concerning the injuries and the right way to attitudes and behavior that will help them to avoid the risk for injuries' occurrence. More specifically, the theoretical framework underlying the teaching proposal includes approaches of behaviorism (Komis, 2004), the structural constructivism and sociocultural learning theory (Solomonidou, 2006). In some activities the pupils are asked to think and solve problems through cognitive conflict. Several of the activities guide the students in the construction of new knowledge, while other activities emphasize on social interaction and the role played by the social and cultural environment, as expressed through symbolic systems, to the establishment of knowledge. Moreover, the teaching methodology which was chosen for this program consists of brainstorming, role playing, dialogue and action in the field. As for the students of the control group, at the same period, they did not attend any extra lessons except the defined ones from the Ministry of Education.

Finally, after the 10-week period, all the students, from both the intervention and the control group, filled in the same questionnaires in order to examine the knowledge, attitude and behavior towards injuries' occurrence.

#### Health education program

##### 1<sup>st</sup> and 2<sup>nd</sup> Session (2-hour classes)

*Aim:* To show pupils the content of the teaching scenario, stimulate their interest and ensure their active participation.

*1<sup>st</sup> activity:* Presentation of pictures of children running and dropping on a wet floor and the dangers they face, with sound effects on the topic. Instructions: Observe and express your opinions concerning these dangers, as well as the correct behavior.

*2<sup>nd</sup> activity:* Presentation of the above activity as a story. Purpose: the better understanding of important data concerning accidents – the pupils know the heroes and more specifically “Mr. Look after” and “Mr. Stumble”.

*3<sup>rd</sup> activity:* The students draw cards with symbols regarding slippery floors and the risks of it, which were posted in various parts of the school, to remind the risks. Discussion about the safety rules to be obeyed when walking at school and when playing with schoolmates. Purpose: to conclude that it is absolutely necessary and useful primarily to recognize the dangers.

##### 3<sup>rd</sup> and 4<sup>th</sup> Session (2-hour classes)

*Aim:* The learning of the two main "stop" signs referring to the "wrong" behaviors in school environment which are particularly dangerous.

*1<sup>st</sup> activity:* Connection with previous intervention. Presentation of pictures of children running down the school stairs and the dangers they face, with sound effects on the topic. Instructions: Observe and express your opinions concerning these dangers, as well as the correct behavior.

*2<sup>nd</sup> activity:* Representation from pupils, of what can happen at the school stairs when someone runs and is not careful both for themselves and for others. In addition, presentation by the teacher of the right attitude and behavior concerning the area of the school stairs. Pupils were photographed during the representation of wrong and correct behavior.

*3<sup>rd</sup> activity:* Pupils try to depict in paintings the risk of wrong behavior concerning the stairs.

##### 5<sup>th</sup> and 6<sup>th</sup> Session (2-hour classes)

*Aim:* To teach pupils to use properly electrical devices in order to avoid the risk of electric shock. Place: Laboratory of the lesson of “Autonomous Living”, a simulation of a house.

*1<sup>st</sup> activity:* Presentation of pictures of people who do not use properly electrical devices and the dangers they face, with sound effects on the topic. Instructions: Observe and express your opinions concerning these dangers, as well as the correct behavior.

*2<sup>nd</sup> activity:* Presentation of the risks resulting from the improper use of household appliances by using the equipment of the laboratory. It was emphasized that pupils: must be very careful when placing the electrical device cord because there is a risk of electric shock, must not touch plugs with wet hands, and must place the cord by holding it by the plastic edge. The teacher of the “Autonomous Living” lesson photographed the pupils during the correct and wrong use of electrical devices in order to put them onto the appliances by the end of the program.

*3<sup>rd</sup> activity:* With the help of the teacher, pupils dramatize a play in the Autonomous Living workshop, representing life in the house with "parents" to advise the "children" as for the correct behavior concerning the use of appliances.

#### 7<sup>th</sup> and 8<sup>th</sup> Session (2-hour classes)

*Aim:* To teach pupils to use properly electrical devices such as electric cooker, electric iron, kettle, through which heat strokes and severe burns may be caused. Place: Laboratory of the lesson of “Autonomous Living”, a simulation of a house.

*1<sup>st</sup> activity:* Presentation of pictures of people who do not use properly electrical devices such as stove, iron, etc., and the dangers they face, with sound effects on the topic. Instructions: Observe and express your opinions concerning these dangers, as well as the correct behavior.

*2<sup>nd</sup> activity:* Learning and practicing ironing and using electric cooker, very carefully and with safety, with the help of the teacher. The risks and the correct way to use were specifically emphasized. Aim: At the end of the activity, the students must know that they should not touch the eyes of the kitchen, the oven and iron soleplate when on operation, because of the risk of suffering serious burns.

*3<sup>rd</sup> activity:* The teacher of the “Autonomous Living” lesson photographed the pupils during correct and wrong use of electrical devices in order to put them onto the Autonomous Living Laboratory, reminding them for the correct and safe use of electrical appliances and protecting from the risk of burn.

#### 9<sup>th</sup> and 10<sup>th</sup> Session (2-hour classes)

*Aim:* To teach pupils to use correctly cleaning agents of household equipment, and their risks. Also, to recognize the special signs which mean "prohibited", "toxic" etc, printed in various cleaners and detergents. Place: Laboratory of the lesson of “Autonomous Living”, a simulation of a house.

*1<sup>st</sup> activity:* Presentation of pictures of people who do not use properly cleaning agents of household equipment such as chlorine (bleach), alcohol, detergents, etc., and the dangers they face, with sound effects on the topic. Instructions: Observe and express your opinions concerning these dangers, as well as the correct behavior.

*2<sup>nd</sup> activity:* Presentation-interpretation of various specific signs of cleaning agents and detergents. Aim: Understanding of the multitude of the specific signs of the cleaning agents.

*3<sup>rd</sup> activity:* Pupils try to depict in paintings the various specific signs. The meaning of the signs was emphasized, starting from those with the serious consequences to the body.

#### Data Analysis

For the data processing *descriptive analysis* was used. Moreover, it was applied the *chi square test* ( $\chi^2$ ) in order to explore possible correlations between qualitative variables. The level of significance was set at  $p < 0.05$ .

### 3. Results

From the results it was found that most students (70 %) have suffered from an injury in their life, while 30 % of the students haven't (Figure 1).

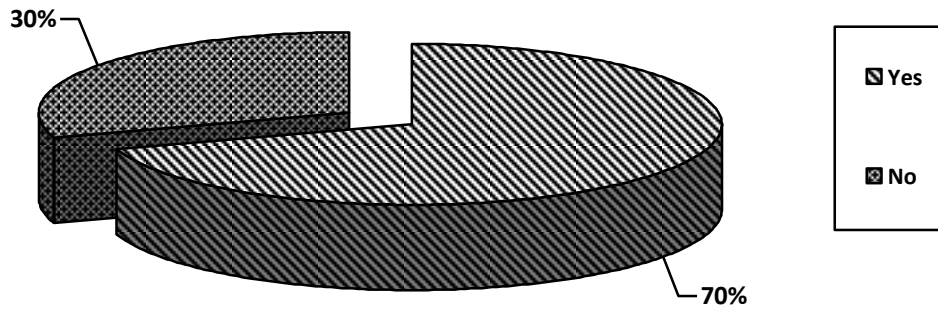

**Fig. 1.** Injury occurrence

In addition, in [Figure 2](#), the place where the latest injury of the students happened is presented.

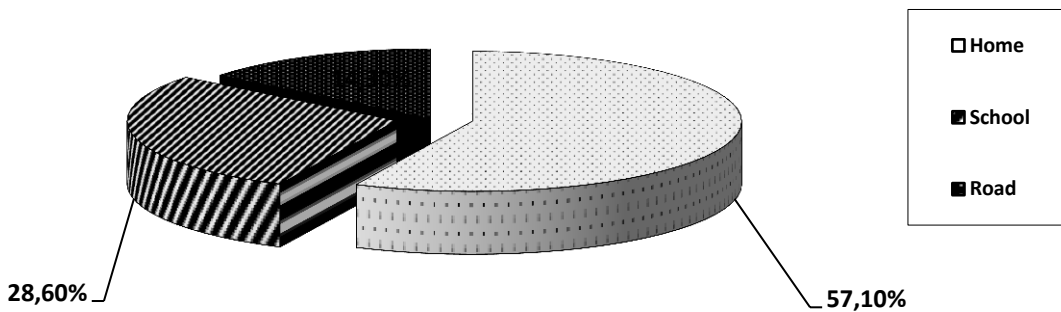

**Fig. 2.** The place where students' latest injury happened

According to the majority of the sample (57.1 %), their latest injury happened at home, while for a significant proportion (28.6 %) the latest injury happened at school. Furthermore, a percentage of 14.3 % state that the latest injury happened on the street ([Figure 2](#)). In [Figure 3](#), are presented the places of the school where the injuries of the students occurred.

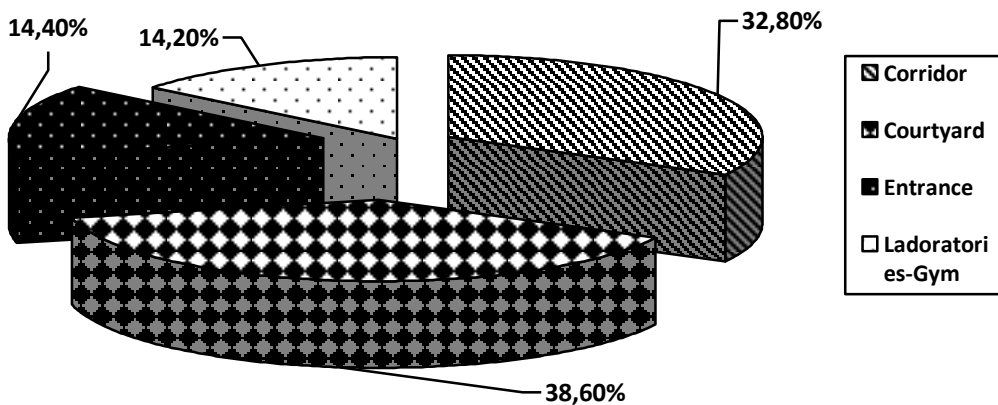

**Fig. 3.** The place at school where the injury happened

As for the places at school where the injuries happened, according to students' statements they happened, in order, in the school courtyard during break time (38.6 %), in the corridor area (32.8 %), in the school entrance (14.4 %), as well as in laboratories and gym during physical education lessons (14.2 %) ([Figure 3](#)). In addition, in [Figure 4](#) is presented the kind of students' injuries that happened in the school environment.

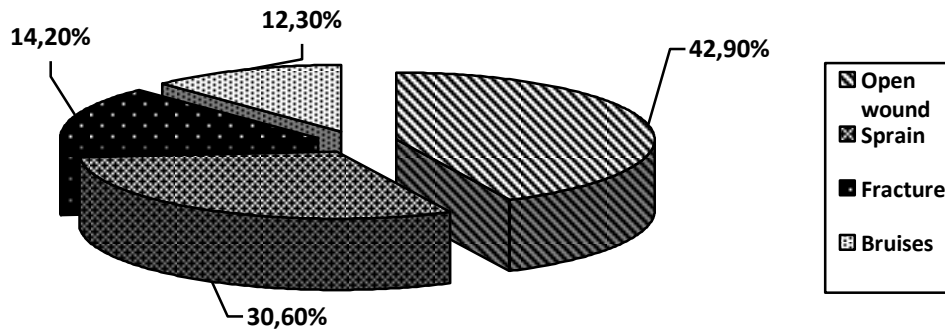

**Fig. 4.** The kind of injuries in the school environment

As it is shown in [Figure 4](#), the largest percentage of students (42.9 %) state that their injuries have caused an open wound in various parts of the body. 1/3 of the students (30.6 %) declare they have suffered a sprain. Moreover, the students report in smaller percentages (14.2 % and 12.3 %) as injuries during their accidents fractures and bruises, respectively. In [Figure 5](#), injuries' causes are presented.

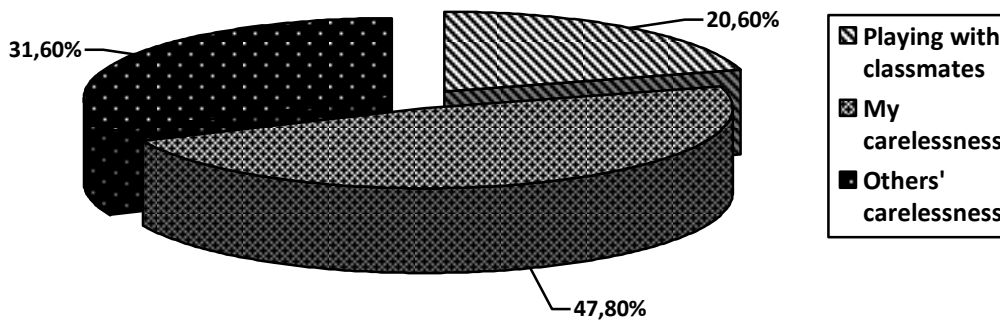
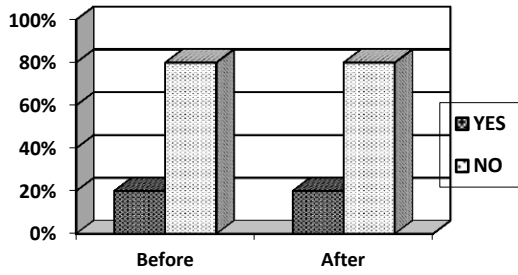

**Fig. 5.** The cause of the injuries in the school

As it is shown in [Figure 5](#), almost half of the students (47.8 %) consider as the key factor leading to injuries in the school their own carelessness, while 31.6 % consider as a determinant others' carelessness. Finally, a significant proportion (20.6 %) of the sample reported that playing with other children in school is a factor that causes injuries ([Figure 5](#)).

From [Figures 6a-12b](#) below, it is shown the significant effect of student's participation in the health education program for injuries' prevention. Regarding the control group, the results showed that after the 10-week period, the students had not changed their knowledge, attitudes and behavior towards injuries. On the contrary, the students of the intervention group, after participating in the 10-week health education program, acquired knowledge regarding possible dangers when they are not careful, and this becomes apparent in [Figure 6b](#). In addition, the students of the intervention group understood that they should not run in the school property or at home ([Figure 7b](#)), as well as that they should not push others ([Figure 8b](#)). Moreover, students understood that they should not step or run on wet floor ([Figure 9b](#)). They also understood that they should be careful for themselves and for their peers in order to prevent injuries ([Figure 10b](#)). In addition, they learned how to use electrical appliances and cleaning agents of household equipment properly and with safety ([Figure 11b](#) and [Figure 12b](#), respectively).

**DO YOU KNOW THE RISKS WHEN YOU ARE NOT CAREFUL?**



**Fig. 6a.** Control Group

**DO YOU KNOW THE RISKS WHEN YOU ARE NOT CAREFUL?**

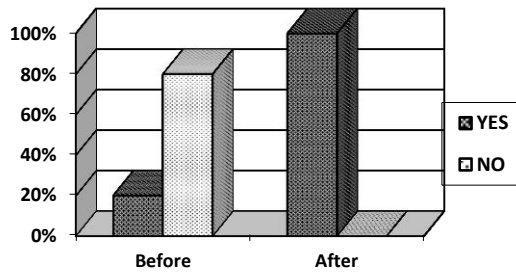

**Fig. 6b.** Intervention Group

**SHALL WE RUN AT SCHOOL OR AT HOME?**

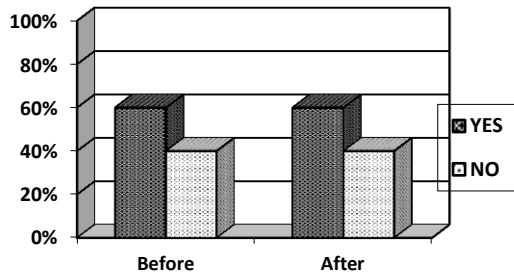

**Fig. 7a.** Control Group

**SHALL WE RUN AT SCHOOL OR AT HOME?**

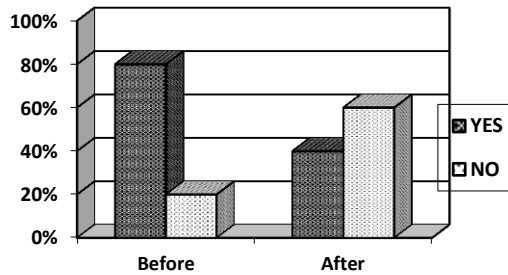

**Fig. 7b.** Intervention Group

**SHALL WE PUSH THE OTHERS?**

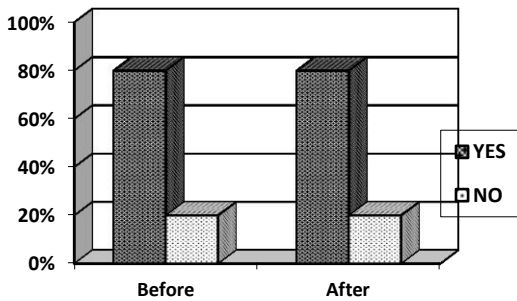

**Fig. 8a.** Control Group

**SHALL WE PUSH THE OTHERS?**

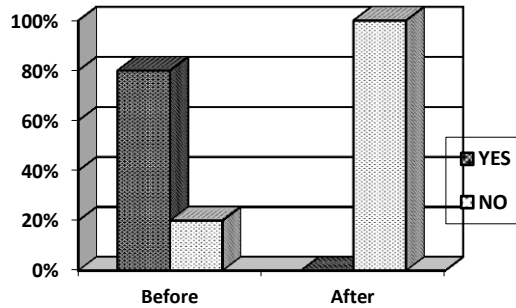

**Fig. 8b.** Intervention Group

**SHALL I STEP OR RUN ON WET FLOOR?**

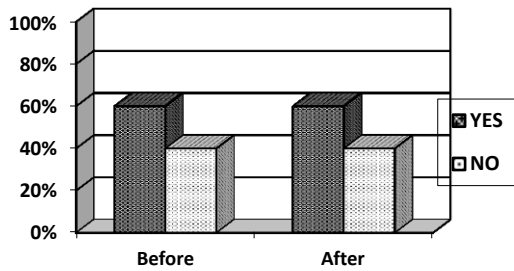

**Fig. 9a.** Control Group

**SHALL I STEP OR RUN ON WET FLOOR?**

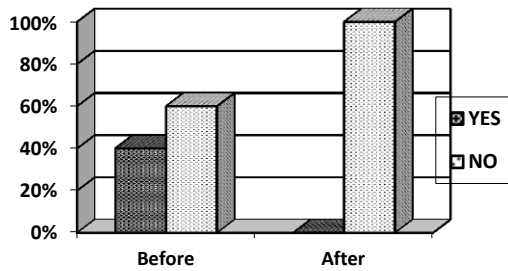

**Fig. 9b.** Intervention Group

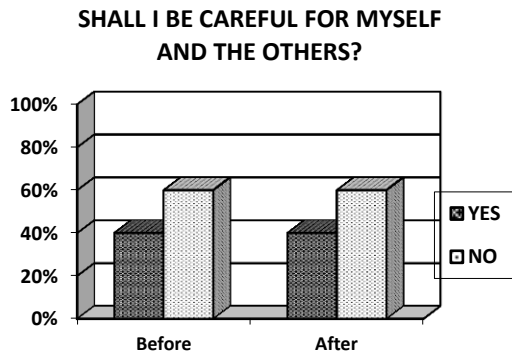

Fig. 10a. Control Group

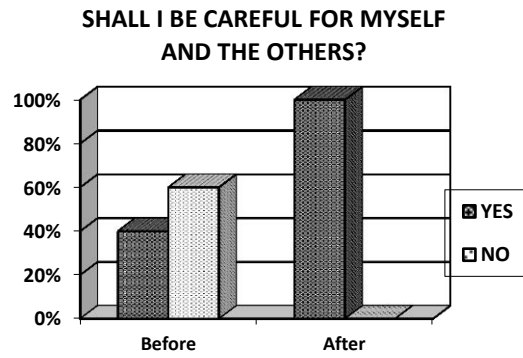

Fig. 10b. Intervention Group

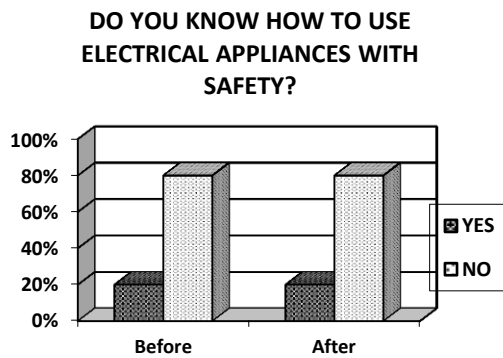

Fig. 11a. Control Group

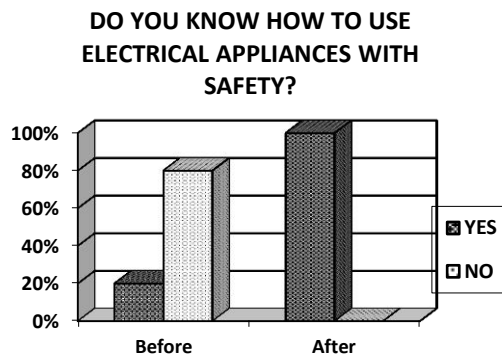

Fig. 11b. Intervention Group

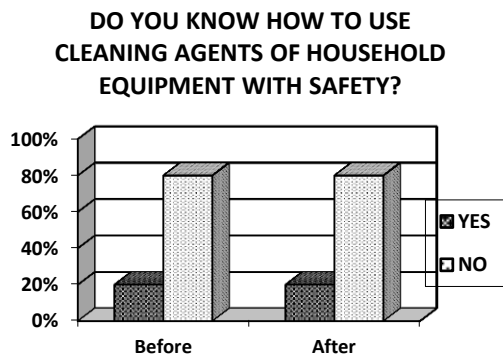

Figure 12a. Control Group.

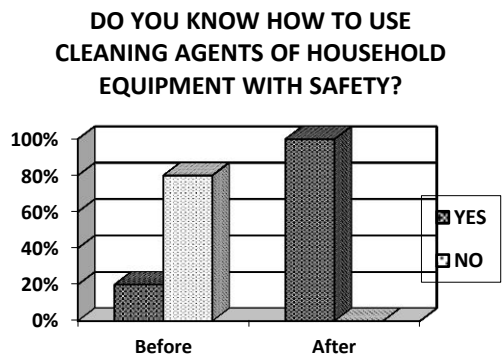

Figure 12b. Intervention Group.

In addition,  $\chi^2$  *crossstabulations* were carried out in order to examine the effect of the group on some of the qualitative variables. The results showed a very significant effect of the group in variables for injury prevention (Table 1).

Table 1. The effect of the group in variables for injury prevention

Variables	Pearson $\chi^2$	p	Cramer's V
"Do you know the risks when you are not careful?"	6.667	<0.05	0.816
"Shall we push the others?"	6.667	<0.05	0.816
"Shall we step or run on wet floor?"	4.286	<0.05	0.655
"Shall I be careful for myself and the others?"	4.286	<0.05	0.655
"Do you know how to use electrical appliances with safety?"	6.667	<0.05	0.816
"Do you know how to use cleaning agents of household equipment with safety?"	6.667	<0.05	0.816



Thus, the  $\chi^2$  test proved a very significant effect of the participation in the health education program regarding injury prevention, the knowledge and the right attitude and behavior of the students towards it.

Therefore, the effect of the participation in the intervention program was very important since the intervention group understood the existence of risks and how to behave in specific situations in order not to be exposed to risks. On the contrary, the control group, with respect to knowledge of the existence of risks and its behavior, did not change at all.

#### 4. Discussion

From the literature review it became clear that injuries of individuals aged 1-24 years are a very important issue, since they are the leading cause of morbidity and mortality in these ages, and a major cause of ill health (Kendrick et al., 2013; Orton et al., 2016; UNICEF, 2013; WHO, 2008). Disabled children, indeed, have higher injury rates than non-disabled children out of school, as well as in the school environment (Ohito et al., 1992; Ramirez et al., 2004; Snyder, Hoffman, 2001; Woring, 1995).

In agreement, from the results of the present research it was found out that the highest percentage of the students with special needs, who participated in the present research either in the control group or in the intervention group, had previously been exposed to injuries from accidents (70 %). According to the students, their latest injury occurred at home (57.1 %), at school (28.60 %) or/and on the road (14.30 %), percentages that are in accordance with the statistics of Hellenic Ministry of Health and Welfare (2002). Thus, it could be said that child accidents can happen anytime and anywhere, including at home, at school, on the street, as well as the playground (Vrynas, 2010).

Moreover, from the injuries in the school, the highest percentage (38.60 %) occurred in the school play yard, in the corridor (32.80 %), at the entrance (14.40 %), and during laboratory courses, as well as physical education lessons (14.20 %). Indeed, in Greece, school play yard considered the most dangerous injuries area (45.52 %), in conjunction with accidents occurring in the corridor and stairs (8.95 %), while the most serious accidents occur during the breaks (60.17 %) and physical education lessons (10.57 %) (Georgiakodis, Vozikis, 2004). In agreement, surveys in schools of Sweden and Poland, showed that the largest number of school injuries happen during breaks and physical education lessons (Hammarström, Janlert, 1994; Schelp et al., 1991; Sosnowska, Kostka, 2003). In addition, Petridou et al. (2003) in their research found that 21.9 % of the disabled group referred that their accident was caused during the courses.

For the sample of the present research, the most common injury in school is the open wound (42.90 %), sprain (30.60 %), fracture (14.20 %) and bruises (12.30 %). Similar percentages with respect to the kind of injury reported, also, in their research Petridou et al. (2003) in students with disabilities. Moreover, a survey in schools in Alexandria of Egypt showed that fractures account for 23 % of school injuries (Kamel et al., 1998). In addition, according to the students of the present research the cause of the injury was mainly their own carelessness (47.80 %), the carelessness of the other students, (31.60 %) and playing with other children at school (20.60 %). In agreement, Petridou et al. (2003) recorded that most students with disabilities are injured while playing with their peers (66.9 %). Thus, aggressiveness, impulsivity and hyperactivity that children often exhibit have been found to be important factors in child injuries (Bijur et al., 1986).

Therefore, facing the important issue of child injuries, it is understood that strategies to prevent and cope with accidents and injuries are required (Zamani et al., 2007). In addition, a meta-analysis of Shi et al. (2015) on unintentional injuries in children with disabilities concluded that injury prevention among children with disabilities, both unintentional and intentional injury, merits attention in the injury prevention field. In agreement, in a research in the province of Rockland, New York, where an injury prevention program was implemented in children for three years, a large decrease in injuries was observed during the second half of the educational/training phase (Schlesinger et al., 1966).

Successful strategies, of course, require the study of incidents or knowledge of what injuries occur, to whom, where, how, when and why (Zamani et al., 2007). That is exactly what has been implemented with the health education program for the prevention of injuries in the present study. Thus, with the intervention of the health education program for the prevention of injuries safety

skills, behavior/practices and knowledge about the injuries of the students with special needs, of the present research who were involved in the project, have been achieved.

So, as a result of their participation in the health education program for the prevention of injuries, the students acquired knowledge regarding possible dangers when they are not careful, understood that they should not run at the school grounds, push others, walk and/or run on wet floor. In addition, they learned how to use the household electrical appliances and cleaning agents properly and with safety, and that they must be careful for themselves but also for their classmates in order to prevent injuries. On the contrary, the students of the control group did not change at all their knowledge, nor their attitude and behaviour toward injuries.

In agreement with the present results, statistically significant changes in children's behavior and attitudes towards safety was reported after oral presentation programs at school, covering a wide range of injury prevention areas on the road, at home and outdoors (Azeredo, Stephens-Stidham, 2003; Pearson et al., 2012). Moreover, statistically significant changes in children's playground safety attitudes were also reported following programs that used an oral presentation and activities to focus on particular aspects of risky playground behavior and by using a video about risky playground behavior that was designed to evoke fear (Morrongiello, Matheis, 2007; Morrongiello, Mark, 2008; Pearson et al., 2012).

Thus, it could be said that school-based educational programs for the prevention of injuries could improve safety skills, behavior/practices and knowledge in children and young people without (Orton et al., 2016) or with special needs and disabilities. It should therefore be noted that most schools could benefit from the application of school programs that include preventing injuries and accidents, according to a research in adolescent students in Louisiana (Louisiana Public Health Institute, 2011). In agreement, from the results of the present study it was concluded that the effect of the participation in the health education program for injury prevention was very important, as students with special needs who participated in the program understood the existence of risks and how to act and behave in certain situations, in order not to expose themselves and their peers to risks and to prevent injuries. Consequently, the present study reveals the worth of school-based health educational programs for the prevention of injuries in students with special needs.

## 5. Conclusion

From the present research derived the following conclusions:

- The application and implementation of health education programs for the prevention of injuries may help as for the very important issue of injuries in students with special needs.
- The participation of the students with special needs in health education programs regarding the prevention of injuries leads to the improvement of the knowledge in relation to injuries, as well as the modification of the observed attitudes and behaviour, and thus to injuries' decrease and avoidance.
- Education in health and safety should be a permanent module taught at school-based programs, especially for students with special needs.
- Future research should focus on the implementation of educational programs regarding the prevention of accidents, in parents and people working with pupils with special needs outside the school.

## References

- Azeredo, Stephens-Stidham, 2003 – Azeredo, R., Stephens-Stidham, S. (2003). Design and implementation of injury prevention curricula for elementary schools: lessons learned. *Injury Prevention*, 9: 274-278.
- Bijur et al., 1986 – Bijur, P., Stewart-Brown, S., Butler, N. (1986). Child behaviour and accidental injury 11.966 preschool children. *American Journal of Disability Children*, 140: 487-492.
- Burkett, 1989 – Burkett, K.W. (1989). Trends in pediatric rehabilitation. *Nurs Clin North Am*, 24: 239-55.
- Gaebler-Spira, Thornton, 2002 – Gaebler-Spira, D., Thornton, L.S. (2002). Injury prevention for children with disabilities. *Phys Med Rehabil Clin North Am*, 13: 891-906.
- Georgiakodis, Vozikis, 2004 – Georgiakodis, F., Vozikis, A. (2004). Epidemiology of school accidents: Results from a research in Secondary Education Schools. *Proceedings of the 17th Panhellenic Statistics Conference*, pp. 83-9. Athens: Greek Statistics Institute [in Greek]



- Hammarström, Janlert, 1994 – Hammarström, A., Janlert, U. (1994). Epidemiology of school injuries in the Northern Part of Sweden. *Scandinavian Journal of Social Medicine*, 22: 120-126.
- Hellenic Ministry of Health and Welfare, 2002 – Hellenic Ministry of Health and Welfare. (2002). Annual EHLASS Report Greece 2001. Centre for Research and Prevention of Injuries among the Young. Dept. of Hygiene and Epidemiology, University Medical School. URL: [http://ec.europa.eu/health/ph\\_projects/2001/injury/fp\\_injury\\_2001\\_frep\\_04\\_en.pdf](http://ec.europa.eu/health/ph_projects/2001/injury/fp_injury_2001_frep_04_en.pdf)
- Kamel et al., 1998 – Kamel, M.I., Youssef, R.M., Teleb, N.A., Atta, H.Y. (1998). Epidemiology of school injuries in Alexandria. *Journal of the Egyptian Public Health Association*, 73: 667-690.
- Kendrick et al., 2013 – Kendrick, D., Young, B., Mason-Jones, A.J., Ilyas, N., Achana, F.A., Cooper, N.J., Hubbard, S.J., Sutton, A.J., Smith, S., Wynn, P., Mulvaney, C., Watson, M.C., Coupland, C. (2013). Home safety education and provision of safety equipment for injury prevention (Review). *Evid Based Child Health*, 8(3): 761-939. DOI: 10.1002/ebch.1911
- Komis, 2004 – Komis, V. (2004). Introduction to educational applications of information and communication technologies. Athens: New Technologies Publications [in Greek]
- Leland et al., 1994 – Leland, N.L., Garrard, J., Smith, D.K. (1994). Comparison of injuries to children with and without disabilities in a day-care center. *J Dev Behav Pediatr*, 15: 402-408.
- Louisiana Public Health Institute, 2011 – Louisiana Public Health Institute (2011). Injury and accident prevention among Louisiana Public School Students. URL: [http://www.lphi.org/wp-content/uploads/2016/09/2011-YRBSS-Fact-Sheet-Injury-Prevention\\_Eval\\_Fact-Sheet.pdf](http://www.lphi.org/wp-content/uploads/2016/09/2011-YRBSS-Fact-Sheet-Injury-Prevention_Eval_Fact-Sheet.pdf)
- Morrongiello, Matheis, 2007 – Morrongiello, B.A., Matheis, S. (2007). Addressing the issue of falls off playground equipment: an empirically-based intervention to reduce fall-risk behaviors on playgrounds. *J Pediatr Psychol*, 32: 819-830.
- Morrongiello, Mark, 2008 – Morrongiello, B.A., Mark, L. (2008). “Practice what you preach”: induced hypocrisy as an intervention strategy to reduce children's intentions to risk take on playgrounds. *J Pediatr Psychol*, 33: 1117-1128.
- Ohito et al., 1992 – Ohito, F.A., Opinya, G.N., Wang'ombe, J. (1992). Traumatic dental injuries in normal and handicapped children in Nairobi, Kenya. *East Afr Med J*, 69: 680-682.
- Orton et al., 2016 – Orton, E., Whitehead, J., Mhizha-Murira, J., Clarkson, M., Watson, M.C., Mulvaney, C.A., Staniforth, J.U., Bhuchar, M., Kendrick, D. (2016). School-based education programmes for the prevention of unintentional injuries in children and young people. *Cochrane Database Syst Rev*, 12: CD010246. DOI: 10.1002/14651858.CD010246.pub2
- Papadopoulos, 2005 – Papadopoulos, I. (2005). More safety in schools. Athens: TITAN [in Greek]
- Pearson et al., 2012 – Pearson, M., Hunt, H., Garside, R., Moxham, T., Peters, J., Anderson, R. (2012). Preventing unintentional injuries to children under 15 years in the outdoors: a systematic review of the effectiveness of educational programs. *Injury Prevention*, 18(2): 113-123. DOI: 10.1136/injuryprev-2011-040043
- Petridou et al., 2003 – Petridou, E., Kedikoglou, S., Andrie, E., Farmakakis, T., Tsigas, A., Angelopoulos, M., Dessypris, N., Trichopoulos, D. (2003). Injuries among disabled children: a study from Greece. *Injury Prevention*, 9: 226-230.
- Ramirez, 2004 – Ramirez, M., Peek-Asa, C., Kraus, J.F. (2004). Disability and Risk of school related injury. *Injury Prevention*, 10: 21-26.
- Schelp et al., 1991 – Schelp, L., Ekman, R., Fahl, I. (1991). School accidents during a three school-years period in a Swedish municipality. *Public Health*, 105: 113-120.
- Schlesinger et al., 1966 – Schlesinger, E.R., Dickson, D.G., Westaby, J., Lowen, L., Logrillo, V.M., Maiwald, A.A. (1966). A controlled study of health education in accident prevention: the Rockland County Child Injury Project. *American Journal of Diseases of Children*, 111: 490-496.
- Sherrard et al., 2002 – Sherrard, J., Tonge, B.J., Ozanne-Smith, J. (2002). Injury risk in young people with intellectual disability. *J Intellect Disabil Res*, 46: 6-16.
- Shi et al., 2015 – Shi, X., Shi, J., Wheeler, K.K., Stallones, L., Ameratunga, S., Shakespeare, T., Smith, G.A., Xiang, H. (2015). Unintentional injuries in children with disabilities: a systematic review and meta-analysis. *Inj Epidemiol*, 2(1): 21. DOI: 10.1186/s40621-015-0053-4
- Simpson, Nicholls, 2012 – Simpson, J.C., Nicholls, J. (2012). Preventing unintentional childhood injury at home: injury circumstances and interventions. *International Journal of Injury Control & Safety Promotion*, 19(2): 141-151. DOI: 10.1080/17457300.2011.635208.

Snyder, Hoffman, 2001 – Snyder, T., Hoffman, C. (2001). Digest of education statistics. Washington DC: National Center for Education Statistics. Report No: NCES 2002130.

Solomonidou, 2006 – Solomonidou, Ch. (2006). New Trends in Educational Technology, Constructivism and Modern Learning Environments. Athens: Metaichmio (in greek).

Sosnowska, Kostka, 2003 – Sosnowska, S., Kostka, T. (2003). Epidemiology of school accidents during a six school-year period in one region in Poland. *European Journal of Epidemiology*, 18: 977-982.

Towner, 1994 – Towner, E.M.L. (1994). Unintentional injuries in childhood: A review of the effectiveness of health education and health promotion. Utrecht: Landelijk Centrum GVO.

UNICEF, 2013 – UNICEF (United Nations Children's Fund). (2013). The state of the world's children: children with disabilities. URL: <http://www.refworld.org/docid/51cbe6074.html>

Valletutti, 1984 – Valletutti, P. (1984). Introduction and overview. In P.Valletutti & B.Sims-Tucker Eds., Severely and profoundly handicapped students. Baltimore, MD: Paul H. Brookes.

Vrynas, 2010 – Vrynas, N. (2010). Risk factors for accidents in school environment. Master thesis. University of Crete [in Greek]

WHO, 2008 – WHO (World Health Organization). (2008). World report on child injury prevention. Geneva: WHO Press.

Woringer, 1995 – Woringer, V. (1995). School accidents. *Rev Med Suisse Romande*, 115: 153-156.

Zamani et al., 2007 – Zamani, A.R., Anderson, B., Evinger, S. (2007). Health and Safety in the Child Care Setting: Prevention of Injuries- A Curriculum for the Training of Child Care Providers, Module 2 (2<sup>nd</sup> ed.). Berkeley, CA: The California Department of Education, Child Development Division.

Copyright © 2018 by Academic Publishing House Researcher s.r.o.



Published in the Slovak Republic  
European Journal of Physical Education and Sport  
Has been issued since 2013.  
E-ISSN: 2409-1952  
2018, 6(2): 80-94

DOI: 10.13187/ejpe.2018.2.80  
[www.ejournal7.com](http://www.ejournal7.com)

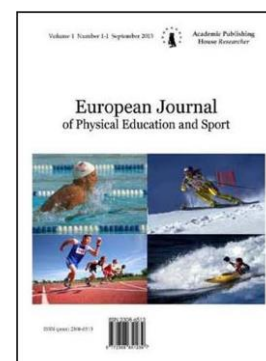

## Exploring of Youth Volleyball Players' Engagement Motivations and Health Related Behaviors

Howard Z. Zeng<sup>a, \*</sup>

<sup>a</sup> Brooklyn College of the City University of New York, USA

### Abstract

As Youth Olympic Summer Games becoming a global sports event in the year of 2010 and be held every four years, research studies demanding about youth volleyball players (YVPs) have become increasingly broader and deeper. The current study examined the essential factors that actually motivated YVPs engaging in practices and competitions and their health relate behaviors using the Adapted Youth Volleyball Players' Motivations and Health Relate Behaviors Questionnaire. Participants were 129 YVPs (age 15-18; 84 males, 45 females; 76 Chinese, 54 American). Data analysis was done by a 2 x 2 x 2 x 2 [Gender (male, female) x Supports (by parents, by-School) x Goal-settings (for-Professional, for-none-professional) x Countries (PRC, USA)] factorial multivariate analysis of variance (MANOVA). Findings including: the top three mean scores among the 19 Motivation factors (MFs) are: MF1 "Unique value"  $M = 4.379 \pm .792$ ; MF3 "Healthier body"  $M = 4.302 \pm .973$ ; RF11 "Foster self-esteem"  $M = 4.212 \pm .878$ ; the MANOVA revealed: 'Gender' and 'Goals-setting' did not reach significant different ( $p > .05$ ) level but the 'Supports' and 'Countries' did. The follow-up 2 x 2 MANOVA discovered: In 'Supports' aspect, 5 out of 19 comparisons showed significant differences ( $p < .05$ ) with 'support by-parents' over 'support by-school'. In 'Countries' aspect, four out of 19 comparisons reached significant differences ( $p < .05$ ) with Chinese YVPs over American YVPs. In conclusion, when examining the YVPs' motivations, 'Gender (male, female)' and 'Goal-settings (for-Professional, for none-professional)' are not the determinate aspects but 'Supports (by-parents, by-School)' and 'Countries (PRC, USA)' aspects are. The findings of this study added a set of fresh data and information regarding the essential MFs that truly motivated the YVPs engaging in practices and competitions, and unique features about these players' health relate behaviors. Meaningful analyses and suggestions are made for the international youth volleyball community that can be used for improving their teaching, coaching and management.

**Keywords:** youth sport, goal setting, support, practice, competition, coaching, management.

### 1. Introduction

The game of volleyball, originally was called "mintonette" and invented by William G. Morgan in 1895 at the Holyoke, Massachusetts, Young Men's Christian Association, USA; where he served as Director of Physical Education. At that time, Morgan's new design for the volleyball game was a combination of basketball, baseball, tennis, and handball (Bellis, 2013). The sport of

\* Corresponding author

E-mail addresses: [hzen@brooklyn.cuny.edu](mailto:hzen@brooklyn.cuny.edu) (H.Z. Zeng)

volleyball is very magnificently balanced between power and speed. Hence while strength and height have become vital components of international teams, the ability of teams and coaches to devise new tactics, strategies and skills have been crucial for success at all significant volleyball competitions (Bellis, 2013). Volleyball game was designed play indoors and in controlled conditions. There are men and women's volleyball events. Volleyball matches should be played to the best of five sets. The first four sets are played to 25 points, with the final set being played to 15 points. A team must win a set by two points. There is no ceiling, so each set continues until one of the teams gains a two-point advantage (Ducksters, 2015; FIBV 2018).

Over the years, both male and female USA volleyball teams are always one of the best teams on the three major volleyball international competitions (including World Cup, World Championship and Olympic Game). USA men and women volleyball teams have won multiple titles in these three major international competitions (E.g., the 1984 Los Angeles Olympics, the 1988 Korea Olympics, the men's team won the gold, etc.). Today, there are more than 800 million volleyball players worldwide, with 46 million of them in the U.S. (Ducksters, 2015; FIBV 2018; Frank, 2015). For playing volleyball and their accomplishment, the Chinese men were not as good as their women sibling, the Chinese women volleyball team become one of the best volleyball teams on the earth since the 1980s; by far they have accomplish nine championships titles in all three major international competitions of volleyball, including World Cup four times (1981, 1985, 2003 and 2015), World Championship twice (1982, 1986) and Olympic Game titles three times (1984, 2004 and 2016) (Wikipedia, 2018).

As Youth Olympic Summer Games becoming a global sports event in the year of 2010 and been held every four years, research studies demanding about youth volleyball players (YVPs) have become increasingly broader and deeper (Official Report, 2010). Even though research literature in youth sports have pointed out that, the goals and reasons of engaging in youth sports practices and competitions including: 'enjoyment', 'physical health', 'having fun', 'foster self-esteem', 'friendship', 'passion or love the game', and 'peer acceptance', 'to contest winners', 'to become a coach', 'to satisfy family's will'; whereas the first three reasons are similar for those participate in the dominant recreational activities of Western societies (Claver et al., 2017; Devine, Lepisto, 2005; Smith et al., 2006; Wikipedia, 2018; Zeng, Meng, 2017). Moreover, Miguel and Machar (Miguel, Machar, 2007) indicted that motivation supports a successful sport performance; representing one of the most important psychological skills in the game he/she is playing. Based on those findings, we are concerning: whether or not nowadays YVPs engage in their practices and competitions really motivated by those factors/reasons (RFs) as been described above? Even despite this, the previous research studies in youth sports involved youth volleyball players' engagement motivations and health related behaviors were still extremely inadequate.

### 1.1 Purpose and Hypotheses

From the introduction and background in youth sports research above, although some of the reasons have been known in general, little is known, however, about what kinds of RFs that actually motivated those YVPs who actually engaged in practices and competitions. Therefore, the purpose of this study was: to explore and examine what RFs truly motivated the YVPs who continually engaged in volleyball practices and competitions. The following specific hypotheses guided our study: (a) no significant differences would be found on the motivation RFs between male and female participants; (b) no significant differences would be found on the motivation RFs between the participants who financially 'Support by-parents or by-school'; (c) no significant differences would be found on the motivation RFs between the participants who set their 'Goal for-professional or for-non-professional'; (d) no significant differences would be found on the motivation RFs between the participants who come from PRC (Peoples Republic of China) or USA. Additionally, what would be the features of health related behaviors on 'Eating habits', 'Nutrition knowledge and status', 'Risk behaviors', and 'Hygiene behaviors' of the participants? The findings from this research would reveal and add a fresh set of data and first-hand description into the youth athletes study literatures, especially concerning youth volleyball players' engagement motivations and their health related behaviors during their volleyball practices and competitions.



## 1.2. Theoretical Framework

A comprehensive theoretical framework named 'self-determination theory' (SDT) (Ryan, Deci, 2000) was employed as the theoretical frame of the current study. The SDT is consisted of two major branches: the theory of intrinsic motivation and the theory of extrinsic motivation. Ryan and Deci (Ryan, Deci, 2000) pointed out: humans are motivated by three basic psychological needs: competence, relatedness, and autonomy. The competence needs in the SDT model is called effectiveness motivation; the relatedness need refers to people's need to belong and to feel accepted by others; the autonomy need, however, refers to people's need to feel self-determined, which is the source of their own action (Ryan, Deci, 2000).

With regard to the organismic needs energize intrinsic and extrinsic motivations, Researchers had similar view: the concept of need in itself is too general and too vague to illustrate the engagement in particular behaviors; to guide empirical research is difficult as well. With this concern, researchers developed a few models describing how different motivations triggered by need manifest in intrinsic and extrinsic motivation in specific aspects or activities (Cox, 2011; Harter, 1981; Pintrich, Schunk, 2002). Stipek (Stipek, 1996) indicated that the research literature is quite consistent with regard to the benefits of intrinsic motivation to learning and development; that is, engagement based on intrinsic motivation does not need external incentives or rewarding and is able to enhance the motivations necessary to engage in the same activity again and again in the future. Kaplan (Kaplan, 2010) further illustrated that engagements based on intrinsic motivations are connected with enhanced comprehension, creativity, cognitive flexibility, accomplishment, and so on.

Additionally, Breese (Breese, 1998) clarified that athletics' initial motivation should be defined as intrinsic motivation (engage in sport for enjoyment) or extrinsic motivation (engage in sport to win rewards). Breese (Breese, 1998) further illustrated, athletics' initial motivation usually predicts athletes' attendance and adherence to a particular sport. Such as in the present study, a youth volleyball player who is intrinsically motivated would be those who go to play or practice his/her skills every other day for fun; whereas a volleyball player who is extrinsically motivated would be those who goes to practice his/her volleyball skills to become a better player at the competition so that he/she could win rewards at competitions. It is interesting to know that intrinsic and extrinsic motivation have different effects on an athlete; whether or not he/she continues the sport he/she had chosen.

Similarly, Researchers explained that individuals who were mainly motivated by competence (engaging in practices to improve skills) and enjoyment (desire to have fun and enjoyment) could be primarily defined as being motivated intrinsically. On the other hand, extrinsically motivated individuals are those behaviors performed in competitions aimed at obtaining rewards or consequences that are unconnected from the behavior itself (Ryan et al, 1997). More specifically, Breese (Breese, 1998) explained that, when athletes begin participation in a particular sport, they are motivated not only by intrinsic factors but also by extrinsic factors. Some particular sports, however, may be more dependent on *intrinsic motivation* than *extrinsic motivation* (Ryan, Deci, 2000). The reasons are: different types of sports need different types of motivation (Breese, 1998; Ryan et al., 1997). In the present study, we were trying to find evidences or factors that have actually motivated the youth athletes who have engaged in the sport of volleyball for numbers of years.

Additionally, in regard to how educators (coach or teacher) apply the "self determination theory" to enhance their coaching or teaching, researchers in their literature review indicated that: when certain important variation exists, there seems to be a widespread consensus between researchers and educators that enhancing intrinsic motivation among youth athletes is beneficial (Cox, 2011; Kaplan, 2010). Youth athletes' intrinsic motivation is enhanced when practices promote their sense of personal autonomy, team or schoolwork are challenging and relevant to them, social relationships are supportive, and environments are physically and psychologically safe (Cox, 2011; Kaplan, 2010). Likewise, practices that promote these environmental characteristics include providing youth athletes with choices among activities and between ways of completing tasks, encouraging youth athletes to explore and pursue their ambition, building on their backgrounds and prior experiences in constructing tasks, encouraging them to collaborate, incorporating fantasy in activities, providing feedback that is informative and frequent, and reducing external rewards (Kaplan, 2010).

Similarly, in many cases, youth athletes are required to engage in tasks that they are not motivated in or not understand why they have to do. Under such circumstances the extrinsic motivations should be implemented to those tasks. However, coaches / teachers should pursue the internalization of youth athletes' extrinsic motivation for these tasks, this can be supported by providing specified examples or demonstrations; coaches should make the value of the tasks explicit and clear (Harter, 1981).

## 2. Methodology

The participants in the current study were purposefully selected from fourteen high schools wherein eight were selected from the city of Nanjing, PRC and six were selected from New York City, USA. All schools selected are public school and had a volleyball varsity team and took part in citywide high school volleyball competition (or championship) regularly (Chinese Middle School Sports Association, 2017; Pintrich, Schunk, 2002).

### 2.1 The Instrumentation

The Adapted Volleyball Player's Motivation and Health Related Behaviors Questionnaire (AYVPMHRBQ) was employed for data collection (Zeng, Meng, 2017). The reasons for using this instrument were: a) an existing questionnaire with similar purposes is available; b) to develop a new questionnaire, time and funding are needed; c) specialists in youth players' motivation and health-related behaviors study are available to revise the wordings to fit in using for youth volleyball players; and d) research assistants and youth volleyball coaches are available for distributing and collecting the questionnaires.

As a result, the AYVPMHRBQ (Zeng, Meng, 2017) contained three parts: Part I requested 'General Information', containing eight questions that covered participant's general information. Part II examined, "What reasons/factors motivated you engaging in volleyball practices and competitions continually" with 19 reasons/factors (RFs) provided. For each RF, the participants can respond to a 5-points *Likert-type scale* (5-points represents "Very strong fit", 4-points represents "Strong fit", 3-points represents "Fit", 2-points represents "Somewhat-fit" and 1-points represents "Little-fit"). In short, Part II of the questionnaire contains ten intrinsic motivation factors (items 1, 2, 4, 7, 8, 10, 13, 14, 15, and 17) and nine extrinsic motivation factors (items 3, 5, 6, 9, 11, 12, 16, 18, and 19). In other words, it included the three basic psychological needs (competence, relatedness, and autonomy) that were described by Ryan and Deci (Ryan, Deci, 2000).

Part III checked 27 health related behaviors that were under the following four sub-categories: 'Eating habits', 'Nutrition Knowledge and Status', 'Risk Behavior', and 'Hygiene Behaviours'. To be clearer, these 27 health-related questions or behaviors are belonging to qualitative data, hence, the data were recorded employed frequency and percentage.

All questions or items in the AYVPMHRBQ (Zeng, Meng, 2017) can be found in Table 2, Table 5 and the Appendix A\*. (\*The AYVPMHRBQ has English and Chinese versions, the YVPs from PRC were given the Chinese version. Due to words limitation, Appendix A has been omitted).

### 2.2 Data Collection

The questionnaires were distributed to the participants during a planned practice day of their team by the researchers under the supervision of their coach or administrators. The participants were given their rights to participate or not to participate and the 'confidentiality' of the survey was also well informed. An explanation about how to respond to the questions or the items was also given; then, an envelope for preventing the participant's coach or instructor from viewing how he/she responds to the questionnaires was provided. By this moment, the participants were asked to sign the Informed Consent Form and submitted it back to the researchers. The researchers also informed coaches that, after the study being completed, the overall outcomes of this study would be provided to their teams. As a result, among the 180 questionnaires delivered, 129 were correctly completed and returned to the researchers (return rate = 71.67 %).

### 2.3 Research Design and Data Analyze

The research design and data analyses for this study were: first, to look at the effects of four independent variables on 19 dependent variables, which are 'Gender' (Male, Female), 'Supports' (by-parents, by-school), 'Goal-settings' (for-professional, for-non-professional), and 'Countries' (PRC, USA) at the same time. Therefore, a 2 x 2 x 2 x 2 MANOVA test was employed. The descriptive statistics reflected the general effects of how these participants were motivated to

engage in volleyball practices and competition; and after significant difference findings a follow-up MANOVA test aim at examining where/what differences really exist among the independent variables with related to the 19 dependent variables (Child, 1990). The statistical program SPSS 24.0 was used for the data analysis and processing.

On the other hand, regard to participants' health related behaviors; the Part III of the questionnaire was employed. With a total of 27 questions / behaviors included 'Eating habits', 'Nutrition Knowledge and Status', 'Risk Behaviours', and 'Hygiene Behaviors' four sub areas. Because of the structures and characteristics of these questions / behaviors, frequency and percentage methods were utilized for data analyzing (Child, 1990). The results from this part of investigation were aimed at reflecting the participants' current status of health-related behaviors.

### 3. Results

#### 3.1. Participants' General Information

The following section presents the findings from the current study; all findings were summarized in Table 1 to Table 5. It aims at discover what reasons/factors actually motivated these youth volleyball players to engage the sport; and at reveal their health related behaviors status as well. First, among the 180 questionnaires distributed, 129 were completed correctly and returned to the researchers; that was about 72 percent return rate. Second, data in Table 1 reflected "General Information of the participants". For example: the participants self-reported: heir heights were "for Male = 179 ( $\pm$  11.5) CM" and "for female = 166 ( $\pm$  8.5) CM". They have been officially engaged in volleyball practices and competitions for 1 to 4 years with the "three year = 68 / 52.7 %" as the highest frequency and percentage. They were all current high school students.

It is worth to illustrate that: the YVPs from the PRC high school volleyball varsity teams represent the highest skill and competitive capability in the youth competitive sport system of the PRC. These YVPs in PRC practice five afternoons per week with 120 -150 minutes per section. Morning exercise may be added in depending on different seasons, times of practices for each section may vary (30-40 minutes). Their program goals are: to promote physical education in schools, promote the development of physical education in secondary schools, increase the sport skills and mental health, and strive to cultivate moral, intellectual, physical, and aesthetic standards. Such as all-round development of outstanding sports reserve talents (Chinese Middle School Sports Association, 2017).

The YVPs in USA high school volleyball varsity teams are definitely represent the highest skill and competitive capability in their youth volleyball competitive sport system. Similarly, the YVPs in USA have five afternoon practices per week as well; but the times for each practice section might slightly shorter than those of YVPs from PRC. Their program goals are: "Encourage as many students as possible to participate in athletic games; Promote sportsmanlike conduct in all athletic contests; Maintain essential minimum standards of eligibility; Provide means to settle disputed athletic contests amicably and authoritatively; Conduct appropriate athletic meets and tournaments; cooperate with the State Education Department in fostering educationally sound athletic programs; Adapt rules governing sports contests to the particular conditions governing high school competition; Continually seek data to support rule changes leading to greater safety for high school athletes" (Miguel, Machar, 2007; Pintrich, Schunk, 2002).

Table 1 reflected the general information about the participants of this study:

**Table 1.** Summery of General Information about the Participants ( $N = 129$ , ages = 15-18, 84 male, 45 female, 76 from PRC, 53 from USA)

Number / Questions	Answers / Frequency / Percentage
1. What is your gender?	a) Male = 84 / 65.1% b) Female = 45 / 34.9%
2. What grade level are you currently going to?	a) 9 – 10 grades = 49 / 37.98% b) 11-12 = 80 / 62.02%
3. How long have you officially play volleball?	a) One year = 15 / 11.6% b) Two years = 31 / 24% c) Three year = 68 / 52.7% d) Four years = 15 / 11.6%
4. What is your Height (CM)?	



- a) Mean for Male = 179 ± 11.5 CM    b) Mean for Female = 166 ± 8.5 CM
5. What is your Weight (KG)?  
 a) Mean for Male = 65 ± 9.5 KG    b) Mean for Female = 59 ± 11.5 KG
6. What is your age-range?    a) 15-16 = 52 / 40.31%    b) 17-18 = 77 / 59.69%
7. Financially, who supported you engaged in volleyball practices and competitions?  
 a) By my parents = 59 / 45.7%    b) By my school /team = 70 / 54.3%
8. What is your goal of engaging in volleyball practices and competitions?  
 a) For become a competitive volleyball player = 50 / 38.3%  
 b) For play better volleyball but not a competitive volleyball player = 79 / 61.2%

The means score and the standard deviations were presented in [Table 2](#):

**Table 2.** Motivation factors (MF) that motivated the youth volleyball Players: Mean scores and standard deviations (S.D.) ( $N = 129$ , Ages = 15-18, 84 Male, 45 Female, 76 from PRC, 53 from USA)

Motivation Factors (MF)	Mean ± S.D.	Sum	Rank
MF 1 Because volleyball's high technical content and unique value.	4.379 ± .792	565.000	1
MF 2 For the fun and get rid of boredom.	4.186 ± .982	540.000	6
MF 3 For getting healthier whole body	4.302 ± .973	555.000	2
MF 4 For the enjoyment and have happiness.	4.209 ± .844	543.000	4
MF 5 In order to meet my friends.	4.108 ± .877	530.000	8
MF 6 In order to make new friends.	4.069 ± .999	525.000	10
MF 7 In order to contest winners.	4.069 ± .911	525.000	9
MF 8 In order to shape the body.	3.465 ± 1.268	447.000	16
MF 9 In order to improve physical health.	4.139 ± 1.137	534.000	7
MF 10 For the near future may become a professional player.	4.194 ± .984	541.000	5
MF 11 In order to foster self-esteem.	4.212 ± .878	542.000	3
MF 12 In order to improve my own reputation	4.008 ± 1.121	517.000	13
MF 13 In order to establish prestige among my friends.	4.069 ± 1.169	525.000	11
MF 14 In order to get the recognition from my teacher / coach.	4.031 ± 1.082	520.000	12
MF 15 In order to reduce the learning / working pressure.	4.000 ± 1.118	516.000	14
MF 16 In order to reduce the troubles from learning / work.	3.969 ± 1.052	512.000	15
MF 17 In order to develop a unique sport skills.	3.170 ± 1.193	409.000	18
MF 18 Hope to become a volleyball coach in the future.	3.147 ± 1.317	406.000	19
MF 19 In order to satisfy the will of family.	3.256 ± 1.106	420.000	17

**Note.** a) The motivation factor (MF) 1, 2, 4, 7, 8, 10, 13, 14, 15, and 17 are 'Intrinsic motivation factors'; b) the MF 3, 5, 6, 9, 11, 12, 16, 18, and 19 are 'Extrinsic motivation factors'

The results of the 2 x 2 x 2 MANOVA for comparing the motivations factors / reasons for the youth volleyball athletes' were presented in [Table 3](#):

**Table 3.** The 2 Gender (male Vs. Female) x 2 Supports (*by-parents vs. by-school*) x 2 Goal-Settings (*for professional vs. for non-professional*) x 2 Countries (PRC vs. USA) factorial multivariate analysis of variance (MANOVA) Tests for youth volleyball players' motivation factors ( $N = 129$ , Ages = 15-18, 84 Male, 45 Female, 76 from PRC, 53 from USA)

Source	Wilks' Lambda	F	Hypo df	Error df	P
Gender	.762	1.591	19.000	97.000	.074

Supports	.731	1.880 <sup>b</sup>	19.000	97.000	.024
Goals	.799	1.281 <sup>b</sup>	19.000	97.000	.214
Countries	.741	1.781 <sup>b</sup>	19.000	97.000	.036

**Note.** 1) Show only for those sources < than 0.5 level; 2) <sup>a</sup> Design: Intercept + Gender + Supports + Goals + Countries + Gender \* Supports + Gender \* Goals + Gender \* Countries; 3) <sup>b</sup> Exact statistic. 4) Supports (*by-parents*,  $n = 59$  vs. *by-school*  $n = 70$ ); 3) Goal-Settings (*for professional*  $n = 50$  vs. *for non-professional*  $n = 79$ ); and Countries (PRC  $n = 76$  vs. USA  $n = 53$ ).

The results in Table 3 showed that: no significant difference in the ‘Gender’ ( $p > .05$ ,  $\Lambda = .762$ ,  $F = 1.591$ ), and no significant difference in the ‘Goal- settings’ ( $p > .05$ ,  $\Lambda = .799$ ,  $F = 1.281$ ); however, significant differences did exist in ‘Supports’ ( $p < .05$ ),  $\Lambda = .731$ ,  $F = 1.880$ , and significant differences did exist in ‘Countries’ ( $p < .05$ ,  $\Lambda = .741$ ,  $F = 1.781$ ) as well. According to the research design, after significant differences effects were found, a following up MANOVA test would be conducted. This post hoc test determined where and what motivation factors that truly motivated these participants engaged in volleyball practices and competitions.

**Table 4.** Descriptive statistics of youth volleyball players’ motivation factors (MF) after significant differences was found in ‘Supports’ and ‘Countries aspects’ ( $N = 129$ , Ages = 15-18, 84 Male, 45 Female)

M F	Supports-by Mean (SD)		Countries Mean (SD)	
	Parents ( $n = 59$ )	School ( $n = 70$ )	PRC ( $n = 76$ )	USA ( $n = 53$ )
MF1.	4.373 ± .807	4.387 ± .785	4.342 ± .809	4.434 ± .772
MF2.	4.186 ± 1.058	4.185 ± .921	4.171 ± 1.050	4.207 ± .884
MF3.	4.457 ± .896	4.171 ± .807	4.434 ± .854	4.113 ± 1.103 *
MF4.	4.254 ± .882	4.171 ± .815	4.210 ± .868	4.207 ± .817
MF5.	4.254 ± .821	3.985 ± .908	4.144 ± .843	4.056 ± .928
MF6.	4.271 ± .925	3.900 ± 1.051	4.220 ± .852	3.942 ± .940
MF7.	4.220 ± .852	3.942 ± .946	4.065 ± .928	4.075 ± .895
MF8.	4.118 ± .948	2.914 ± 1.248 **	3.407 ± 1.297	3.547 ± 1.233
MF9.	4.186 ± 1.106	4.100 ± 1.169	4.210 ± 1.106	4.037 ± 1.239
MF10.	4.271 ± .867	4.128 ± 1.075	4.263 ± .943	4.094 ± 1.042
MF11.	4.389 ± .743	4.043 ± .954	4.276 ± .809	4.064 ± .966 *
MF12.	4.203 ± 1.046	3.842 ± 1.162 *	4.026 ± 1.082	3.981 ± 1.184
MF13.	4.220 ± .966	3.943 ± 1.047	4.026 ± 1.045	4.132 ± .981
MF14.	4.254 ± 1.043	3.842 ± 1.085	3.960 ± 1.136	4.132 ± 1.000
MF15.	4.271 ± .943	3.771 ± 1.205 *	4.019 ± 1.113	4.000 ± 1.135
MF16.	4.254 ± .957	3.728 ± 1.075 *	4.039 ± 1.038	3.837 ± 1.074 *
MF17.	3.220 ± 1.327	3.128 ± 1.076	3.210 ± 1.214	3.113 ± 1.171
MF18.	3.339 ± 1.409	2.985 ± 1.221	3.184 ± 1.303	3.094 ± 1.348
MF19.	3.508 ± 1.072	3.042 ± 1.095 *	3.302 ± 1.006	3.188 ± 1.241 *

**Note.** a) MF = Motivation Factor. b) This was the follow up test to determine what MF and which ‘Supports-by’ and ‘Countries’ exist significant differences. As results, in ‘Supports-by’ aspect, 5 out of 19 comparisons showed significant differences at significant  $p < .05$ \*Level; in which one comparisons reached significant  $p < .01$ \*\* Level. Second, in ‘Countries’ aspect, four out of 19 comparisons reached significant differences at  $p < .05$ \*Level only

Data in Table 4 were from the follow up test, it determined where/what RFs really had differences and reflected the “Factors that truly motivated the youth volleyball players be initially engaged in, and continually engaged in volleyball practices and competitions”.

Major findings: As showed on Table 2, the highest score factors were the following six MFs: MF1 ‘Technical content & unique value’ ( $M = 4.212 \pm .878$ ); MF3 ‘Healthier body’ ( $M = 4.302 \pm .973$ ); MF11 ‘Foster self-esteem’ ( $M = 4.352 \pm 1.114$ ); MF4 ‘For enjoyments’ ( $M = 4.209 \pm .844$ ); MF10 ‘To become a professional-player’ ( $M = 4.194 \pm .984$ ); and MF2 ‘For having fun’ ( $M = 4.186$

$\pm .982$ ), These six factors possessed the highest impact power on these youth volleyball player's motivations. The bottom seven factors' mean score were: MF12 'To improve reputation' ( $M = 4.008 \pm 1.121$ ); MF15 'To reduce pressure' ( $M = 4.000 \pm 1.118$ ); MF16 'To reduce the troubles' ( $M = 3.969 \pm 1.052$ ); MF8 'To shape body' ( $M = 3.465 \pm 1.268$ ), MF19 'To satisfy family's will' ( $M = 3.256 \pm 1.106$ ), MF17 'To develop a unique sport skills' ( $M = 3.170 \pm 1.193$ ); and MF18 'to become a volleyball coach' ( $M = 3.147 \pm 1.317$ ). These seven factors possessed less or lowest impact power on these youth volleyball players' motivations. The other six factors' mean scores were located the medium level. These MFs were: MF9 'To improve physical health' ( $M = 4.139 \pm 1.137$ ); MF5 'To meet friends' ( $M = 4.108 \pm .877$ ); MF7 'To contest winners' ( $M = 4.069 \pm .911$ ); MF6 'To make new friends' ( $M = 4.069 \pm .999$ ); MF13 'To establish prestige' ( $M = 4.069 \pm 1.169$ ); and MF14 'To get recognitions' ( $M = 4.031 \pm 1.082$ ). These six factors possess medium impact power on these youth volleyball athletes' participation motivations.

The findings from the Part III of the AYSAMHRBQ (Zeng, Meng, 2017) were summarized in Table 5:

**Table 5.** Summarize of youth volleyball players' health-related behaviors in the Part III of the questionnaire ( $N = 129$ , Ages = 15-18, 84 Male, 45 Female, 76 from PRC, 53 from USA).

Sub-category one. The 'Eating habits' (6)

1. Do you eat regularly?
  - a) My eating is very regular (67 / 51.94%)
  - b) My eating is regular (43 / 33.33%)
  - c) My eating is unregularly (11 / 8.53%)
  - d) My eating is very unregularly (8 / 6.20%)
2. How many meals do you eat a day?
  - a) Less than 3 times per day (0 / 0%)
  - b) 3 times per day (112 / 86.82%)
  - c) 4-5 times per day (9 / 6.97%)
  - d) Others (8 / 6.20%)
3. Do you add salt to your dishes?
  - a) yes, always (19 / 14.73%)
  - b) sometimes, yes (25 / 19.78%)
  - c) sometimes - no (54 / 41.86%)
  - d) no, I don't (31 / 24.03%)
4. Do you try to cut down on the amount of sugars you eat?
  - a) yes (15 / 11.62%)
  - b) sometimes - yes (45 / 34.88%)
  - c) sometimes - no (45 / 34.88%)
  - d) no, I don't (24 / 18.60%)
5. How many glasses of milk or dairy products (yoghurt, juice) do you drink per day?
  - a) 1-2 cups (67 / 51.93%)
  - b) 3-4 cups (35 / 21.13%)
  - c) more than 5 cups (21 / 16.28%)
  - d) I don't drink milk (6 / 4.65%)
6. Do you dine before and after strenuous exercise?
  - a) Yes (0 / 0%)
  - b) sometimes I do (0 / 0%)
  - c) I occasionally do (7 / 5.43%)
  - d) I never do so (122 / 94.57%)

Sub-category two. The 'Nutrition knowledge and status' (8)

7. How is your knowledge status about nutrition?
  - a) Very good 69 / 53.49%
  - b) good (25 / 19.78%)
  - c) Ordinary (31 / 24.03%)
  - d) Not so good (4 / 3.10%)
8. How often do you eat fruit?
  - a) once per day (58 / 44.96%)
  - b) twice per day (48 / 37.21%)
  - c) more than three times per day (17 / 13.18%)
  - d) Once every other day (6 / 4.65%)
9. How often do you eat vegetables?
  - a) once per day (15 / 11.63%)
  - b) twice per day (89 / 68.99%)
  - c) more than three times per day (15 / 11.63%)
  - d) Once every other day (10 / 7.75%)
10. How often do you eat fish?
  - a) once per day (8 / 6.01%)
  - b) twice per day (8 / 6.01%)
  - c) more than three times per day (0 / 0%)
  - d) Once every other day (113 / 87.59%)
11. Do you eat wholemeal bread?
  - Yes: a) once per day (61 / 47.28%)
  - b) twice per day (28 / 21.70%)
  - c) more than three times per day (0 / 0%)
  - d) Once every other day (40 / 31.01%)
12. How many times do you eat dinner with meat in a week?
  - a) 1-2 times (8 / 6.01%)
  - b) 3-4 times (45 / 34.88%)

- c) more than 4 times (8 / 6.01%)  
 13. What is your favourite meat?  
 a) Chicken (42/ 32.56%)  
 c) Veal / Calf (39 / 30.23%)  
 14. Do you eat fried foods?  
 a) Occasionally eat (67 / 51,94%)  
 c) Yes I like eat fried foods (6 / 4.65%)  
Sub-category three. The 'Risk behaviour' (5)  
 15. How often do you drink alcohol?  
 a) Never (8 / 6.20%)  
 c) once in a while (89 / 68.99%)  
 16. Do you smoke cigarettes?  
 a) Never (71 / 50.04%)  
 c) once in a while (18 / 13.95%)  
 17. Do you use any psychoactive substances?  
 a) Never (129/ 100%)  
 c) once in a while (0 / 0%)  
 18. Did you use anabolic steroid?  
 a) Never (129 / 100%)  
 c) once in a while (0 / 0%)  
 19. Do you know what health consequences to applying prohibited anabolic steroid or different kind of doping substances?  
 a) yes, I know them well (76 / 58.91%)  
 c) No, I am not sure (16 / 12.40%)  
Sub-category four. The 'Hygiene behaviours' (8)  
 20. Do you use sun cream when you play volleyball?  
 a) Never (115 / 89.15%)  
 c) once in a while (0 / 0%)  
 21. Do you take a shower after practicing or competition?  
 a) Yes, of cause I do (121 / 93.80%)  
 c) Mostof time I do (0 / 0%)  
 22. How often do you wash your hands daily?  
 a) One time (0 / %)  
 c) Before every meal (52 / 40 /31%)  
 23. How often do you brush your teeth daily?  
 a) Once per day (0 / 0%)  
 c) Three times per day (26 / 2..16%)  
 24. Do you use extra hygiene mouth?  
 Yes! – circle the things you used:  
 a) Dentist's threads (38/ 29.46%)  
 c) Dental floss (13 / 10.07%)  
 25. After a intensive practice, how was the quality of your sleep?  
 a) Very good (58 / 38.75%)  
 c) Normal (28/ 21.70%)  
 26. After a intensive competition, how is the quality of your sleep?  
 a) Very good (51 / 39.53%)  
 c) Normal (20 / 15.50%)  
 27. When sweating, do you drink water or beverages immediately?  
 a) Yes, I drink water immediately (103/ 79.84%)  
 c) I drink beverages immediately (26 / 20.15%)  
 b) Pork (41 / 31.78%)  
 d) Mutton / Lamb (7 / 5.43%)  
 b) Sometimes eat (36 / 27,91%)  
 d) No, I do not eat fried food (10 / 7,75%)  
 b) seldom (15 / 11.63%)  
 d) whenever have a reason (17 / 13.18%)  
 b) seldom (9 / 6,97%)  
 d) whenever have a reason (31 / 24.03%)  
 b) seldom (0 / 0%)  
 d) whenever have a reason (0 / 0%)  
 b) seldom (0 / 0%)  
 d) whenever have a reason (0 / 0%)  
 b) Yes, I know some of them (30 / 23.25%)  
 d) No, I don't know them at all (7 / 5.43%)  
 b) seldom (0 / 0%)  
 d) whenever have a reason (14 / 10.85%)  
 b) No, (18 / 6.20%), just want to go home ASAP.  
 d) No, because I do not want to (0 / 0%)  
 b) Two to three times (56 / 43.41%)  
 d) Whenever it is need to (11 / 8.53%)  
 b) Twice per day (103/ 79.84%)  
 d) Never (0 / %)  
 b) Teeth Liquids to rinsing (78 / 60.46%)  
 d) No, I never use extra hygiene mouth (0 / %)  
 b) Good (39 / 30.23%)  
 d) Not so good 4 / 3.10%)  
 b) Good (49 / 37.98%)  
 d) Not so good (9 / 6.97%)  
 b) I don't drink any of them immediately (0 / 0%)  
 d) I drink water but not immediately (0 / 0%)

Data presented in Table 5 reflected the unique features and current status of these youth volleyball athletes' health-related behaviors. We believe that these four sub-categories of health-related behaviors are very important to the youth volleyball players and possess a positive

relationship with their successful rate. That is, the better their health-related behaviors, the higher success rate for them to become elite volleyball athletes. Furthermore, from an educational perspective, coaches / teachers / administrators who work for the youth volleyball teams should educate their players / students to gradually develop these positive health related behaviors, so that they can gradually develop or form those health related behaviors. Besides, the following were the significant highline:

A. For the 'Eating habits' sub-category: 1) 52 % of them reported their eating very regularly, only 6 % of them claimed their eating not so normal or regularly; 2) 87 % of them ate 3 meals per day; 3) about 66 % of them no need to add salt to their food / dishes but 34 % of them need to; 4) about 47 % of them did try to reduce the amount of sugars they eat; 5) 73 % of them drink 1-4 cups of milk / yoghurt / juice per day but about 5 % of them did not drink milk / yoghurt / juice; and 6) 95% of them reported they never dine before and after strenuous exercise.

B. For the 'Nutrition knowledge and status' sub-category: 7) 83 % of them reported they possess good to very good nutrition knowledge; 8) 95 % of them said they eat fruit every day; 9) 92 % of them said they eat vegetables every day, 10) 88 % of them reported they ate fish once every other day; 11) 100 % of them reported they eat whole meal bread; 12) 53 % of them reported they eat dinner with meat every day but 6 % of them claimed they eat dinner with meat only 1-2 times per week; 13) as to their favorite meat, the rank order was: Chicken, Veal / Calf, pork, then Mutton / Lamb (with about 5 % of them only); 14) 8 % of them reported they did not eat fried foods.

C. For the 'Risk behavior' sub-category, 15) 6 % of them said they never drink alcohol, 12 % of them reported they seldom drink alcohol, 69 % of them admired they once in a while drink alcohol, and about 13 % of them admired they drink alcohol whenever have a reason; 16) to 19), no need to highline (see [Table 5](#)).

D. For the 'Hygiene behaviors' sub-category, 20) 89 % of them claimed they never use sun cream when they play volleyball (because volleyball is an in-door sport)); 21) 94 % of them said they take a shower after practicing or competition; 22) 100 % of them claimed they wash their hands often or whenever it is needed to; 23) 100 % of them claimed they brush their teeth twice to three times per day; 24) 100 % of them claimed they use extra hygiene mouth, wherein 60 % of them used teeth liquids rinsing, 30 % used dentist's threads, and 10 % used dental floss; 25) 39 % of them claimed they had very good sleep after a intensive practice but 3 % of them said their sleep was not so good; 26) 51 % of them reported their sleep was very good after a intensive competition/game but 7 % of them claimed their sleep was not so good; and 27) 80 % of them said that whenever sweating they drink water immediately and 20 % of them reported whenever sweating they drink beverages immediately.

#### 4. Discussion

The current study was designed for: 1) exploring the current status and features of the YVPs' engagement motivations and their health related behaviors; and 2) examining if differences exist on the motivation factors between the participants' 'Gender (male vs. female)', 'Supports (by-parents vs. by-school)', 'Goal-settings (for-professional vs. for non-professional) and 'Countries (PRC vs. USA)' four aspects.

First, for the "current status and features", according to the data displayed in Table 2, the scores places can be divided into three groups and reflected the current status and features of these participants engagement motivations and their health related behaviors: The high impact factors group, containing MF1, MF3, M11, MF4, MF10 and MF2 possessed the highest score and impact power on this sample's youth volleyball players' motivation. Interestingly, among these six MFs, the MF1, MF4, MF10, and MF2 are in 'Intrinsic factors' category, while the MF3 and M11 are in 'Extrinsic factors' category.

The medium impact factors group with medium high scores, including MF9, MF5, MF7, MF6, M13 and MF14 possessed medium impact power on this sample's youth volleyball players' motivation. Even more Interesting, among these six MFs in this group there are three MFs are in the 'Intrinsic factors' category (MF7, MF13, MF14), and three MFs are belong to the 'Extrinsic factors' category (MF9, MF5, MF6).

The lower impact factors group, containing MF12, MF15, MF8, MF19, MF16, MF17, and MF18 possessed significantly lower impact power on these participants' motivations. Incredibly,



there are three MFs in the ‘Intrinsic factors’ category (MF15, MF8, and MF17), while four MFs are in the ‘Extrinsic factors’ category (MF12, MF19, MF16, and MF18, see [Table 2](#)).

In summary, 1) with regard to this sample’s participants’ motivation features, the ‘Intrinsic factors’ possess higher impact power than those of ‘Extrinsic factors’ on the participants’ motivations; 2) the ten ‘Intrinsic factors’ from the AYSAMHRBQ ([Zeng, Meng, 2017](#)) were the core motivation factors for the participants; 3) some factors or reasons possessed higher impact power than the other factors, and 4) there are also some factors or reasons held less impact power than the others factors. Based on our findings, youth volleyball coaches, trainers or administrators should diagnose and analyze their players’ specific situation and carefully implement the findings accordingly. The motivation features of this sample’ youth volleyball athletes can be summarized as [Figure 1](#).

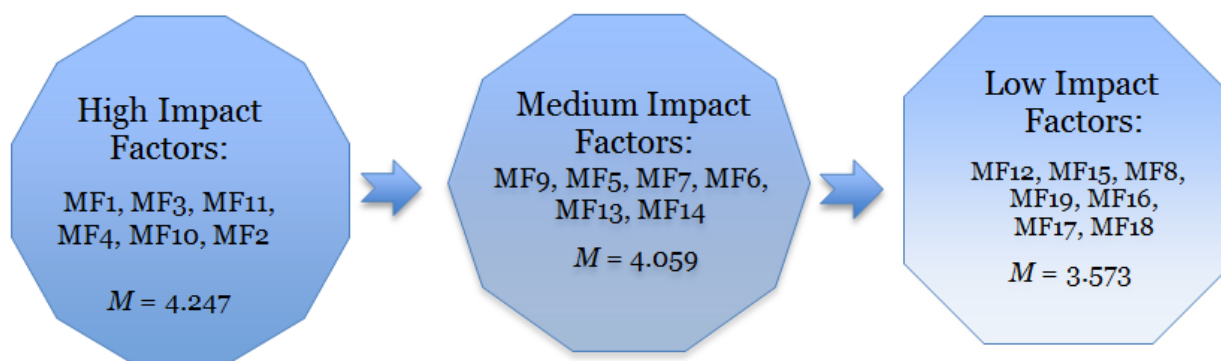

**Fig. 1.** Motivation features of the participants ( $N = 129$ , Ages = 15-18, 84 Male, 45 Female, 76 from PRC, 53 from USA)

**Note.** a) The motivation factor (MF) 1, 2, 4, 7, 8, 10, 13, 14, 15, and 17 are ‘Intrinsic motivation factors’; b) the MF 3, 5, 6, 9, 11, 12, 16, 18, and 19 are ‘Extrinsic motivation factors’; c) The grand mean for all three groups =  $M_{Grand} = 3.960$ , and d) These 19 factors reflected the ‘Competence Needs’, the ‘Relatedness Needs’ and the ‘Autonomy Need’ in the ‘Self-Determination Theory’ model interpreted by Ryan and Deci (2000).

Second, for “the examining if differences exist on the motivation factors among the four independence variables (‘Gender’, ‘Supports’, ‘Goal-settings’ and ‘Countries’) or for the four specific hypotheses, the findings revealed: the first and third hypotheses were true. That were: no significant differences on the motivation factors between male and female volleyball players; and no significant differences on the motivation factors between the volleyball players who set-up a goal ‘for-professional’ or ‘for non-professional’. Although no one can exactly tell what the reasons behind of these are: it probably relates to these high school boys and girls are focusing on their two needs: one is academic learning, and the other one is to develop a unique skill. Play in a volleyball varsity team can satisfy these two needs for those teenagers no matter they are boys or girls. Likewise, it doesn’t matter what goals he or she has set-up (for-professional vs. for non-professional), the reality was he or she has been playing in a varsity team that would be beneficial for his or her future, and so on. In other word, the reaction / responding to the 19 motivation factors by the boys and girls in the two ‘Goal-settings’ (for-professional or for non-professional) were pretty similar, and reflecting they were training by amateur coaches, with similar coaching ideas, management regulations and a common goal; that was, to able to win the competition in a incoming citywide or state wide youth volleyball games ([Chinese Middle School..., 2017](#); [New York State..., 2017](#)).

The second and the fourth hypotheses, however, were not true. That were, participants’ motivations scores did exist significant differences between financially ‘Support by-parents’ or ‘Support by-school’; and the motivations scores between the participants who come from PRC or USA did exist significant differences as well. Furthermore, the following up 2 ‘Supports (by-parents, by-school)’ x 2 ‘Countries’ (PRC, USA) MANOVA test determined where and what MFs that truly motivated these participants engaged in volleyball practices and competitions.

The particular findings were: 1) in the ‘Supports’ aspect, 5 out of 19 comparisons showed significant differences at significant  $p < .05$  level; in which one comparisons reached significant  $p < .01$  level. 2) As to the ‘Countries’ aspect, there were four out of 19 comparisons reached significant differences at  $p < .05$  level only. This finding imply that even if there were 9 out of 38 comparisons reached significant  $p < .05$  level (see Table 4), it did not means those nine MFs play much important roles in the participants’ engagement motivations and other MFs can be ignored. To better develop or improve the participants’ motivations, educators still need to implement the “three needs” – ‘Competence Needs’, ‘Relatedness Needs’ ‘Autonomy Need’ as a whole process interpreted by Ryan and Deci (Ryan, Deci, 2000).

For the reasons why those volleyball players who financially supported by parents scored significant higher than those of supported by school, based on the inside information from those participants’ teams or schools the explanation could be: these players had potentials to become excellent players, he / she had already played important roles in their team; his / her family had rich income, and they know that in near future they will play for higher level’s competitions (e.g., the competition of university varsity or professional level). Plus whenever their teams need financing support from the school, because he / she is one of the important player, his / her expense will be covered. This may the reason why less players selected they were supported by school/team.

As to why the youth volleyball players from PRC scored higher than those from the USA, the inside information from those participants’ teams or schools was: This finding was somewhat surprise, because many peoples expected: players from USA would score higher than from the PRC. In fact that was not true. When comparing the motivation factors differences between the PRC and The USA, people need to keep these in mind: China has much more population, no enough universities / colleges allow young people to be enrolled. Situation in the USA was quite differ: The US is a country own most universities / colleges on the earth, the majority young people in US can go to universities / college if they want to. Other than that, young people in US have other options such as: get a job, create a business, and join the army after their high school graduation. In contrast, youth players in China have much less opportunities go to college, get a job, or create a business; this may cause the Chinese youth volleyball players motivated themselves to work harder and play better volleyball so that volleyball can become their unique skill for accomplish their goal (e.g., get extra scores in college enrollment).

As we stated at the beginning, “research studies involved motivations of taking part in youth volleyball athletes are extremely limited”, this is why we defined the current study as “An exploring ...” Fortunately, after searching the whole database on volleyball players’ motivation topic, one study was found. That is: *The Cognitive and Motivation Intervention Program in Youth Female Volleyball Players*. In this study, the researchers examined 34 female youth volleyball players’ motivations (Claver et al, 2017) using the Self-Determination Theory (Deci, Ryan, 1985; Deci, Ryan, 2002). Their key method or technique was a repeat measures MANOVA [2 (groups: experimental vs. control) x 2 (times: pre-test vs. post-test)]. Groups x times interaction effect was analyzed. Their findings revealed that: significant differences in the post-test measurement between the experimental group and the control group, wherein experimental group obtained higher scores than control group with regard to the following variables: a) basic psychological need satisfaction of autonomy and competence; b) autonomous motivation; c) procedural knowledge; and d) perceived performance and sport-engagement commitment (Claver et al., 2017). Their study provided the relevance of the cognitive-motivational processes, not only for improving youth players’ skill performances but also for understanding participants’ sport engagement commitment; and their intervention programs have important implications for the youth sport coaching as well (Claver et al., 2017).

After all discusses above, what else should we do? Besides certain differences existing between the current study and those previous studies, there are some similarities as well. For example, using the previous studies’ findings for the sport of tennis, soccer, and basketball such as: An review of literature in “Motivation in Tennis” by Miguel and Machar (Miguel, Machar, 2007); and the “Research studies in youth athletes’ participation motivations in soccer, and basketball” by Zeng et al (Zeng, Meng, 2017; Zeng et al., 2016).

First, Miguel and Machar (Miguel, Machar, 2007) summarized that: 1) ‘Enjoyment’, ‘Having fun’, and ‘Passion on the sport’ were rated as top three important motivation factors for the success



of youth tennis players. Second, 'Improving performance', 'Keeping fit' and 'Socializing' were rated as their basic reasons for keeping them involved in the sport. Third, 'Feeling important and popular', and 'Earning rewards' were ranked as lower influence motivations. And last, School / club / team atmosphere and having a good relationship with the coach were also ranked as less or lower important factors on players' motivation (Lippitt, 2012). Simply by checking with the findings of the current study, it is easy to find out that, there are so many similarities.

Second, research findings from youth soccer and basketball by Zeng et al (Zeng, Meng, 2017; Zeng et al., 2016) indicated that: the top six factors were 'Technical content & unique value', 'To meet friends', 'For fun', 'To make new friends', 'For my biography', and 'To establish prestige'; the other six factors, however, possessed less or lower impact power on these youth soccer player's motivation, including: 'Get the recognition', 'To improve health', 'For one unique skills', 'To reduce troubles', 'To be a professional', 'To satisfy family's will'. Furthermore, Zeng, and Meng (Zeng, Meng, 2017) in their "Youth basketball players' motivations" described that: the top six factors were 'Technical content and unique value', 'To develop a extraordinary skills', 'For getting healthier', 'For enjoyment and happiness', 'To improve my own-biography', and 'To improve physical fitness'; these six factors possessed the highest impact power on these youth volleyball players' motivation. These findings were similar to the findings of our findings as well (Zeng, Meng, 2017).

Additionally, due to no study has covered the 'Health-related behaviors' in the youth volleyball topic that we cannot make any comparison about it. This study, then, did an exploring survey in this concern. To the results presented in Table 5, we are not going to make comments on how good or not so good about their 'Health-Related Behaviors', but the findings in Table 5 did reflect the current status of 'Health Related Behaviors' of the participants. Generally speaking, this belongs to a set of qualitative data. Each item in this part provided four options; participant can circle the option that is most match his/her situation. Frequency and percentage in each item was used for reflecting the results.

As a whole, the results implied: 1) during their practices and competitions these youth players obtained correct education in 'Eating habits', 'Nutrition knowledge', 'Risk behaviors', and 'Hygiene behaviors' from their coaches / instructors. 2) There is room for improvement regarding these YVPs' 'Health-Related Behaviors' although their score were reasonably good. 3) The results have also indirectly reflected these youth volleyball teams / schools have strict regulations to manage their athletes' daily life. From health education perspective, we believe that is a positive and beautiful thing deserves to recommend to the other youth sports. From this consideration, our findings are consistent with the point view from a literature review by Geidne, et al. (Geidne et al., 2013); they stated that: build up healthy public policy in youth sports is important, organizations (Teams/schools) of youth sports should recognize and match up with the changes in health regulations at a central level, and then implement these regulations to different types youth sports teams/schools. Regarding all the changes in regulations or policies, there is one thing in common: that is, youth athletes' health must be put in the management agenda (Geidne et al., 2013).

## 5. Conclusion

In conclusion, (a) the following reasons/factors are crucial and play important effects on the YVPs' engagement motivations <sup>-Note:</sup> MF1 'Technical content & unique value', MF3 'Healthier body', MF11 'Foster self-esteem', MF4 'For enjoyments', MF10 'To become a professional-player', MF2 'For having fun', MF9 'To improve physical health', MF5 'To meet friends', MF7 'To contest winners', MF6 'To make new friends', MF13 'To establish prestige', and MF14 'To get recognitions'. Although the other seven MFs in AYSAMHRBQ (Zeng, Meng, 2017) are essential, it is not as powerful and the above 12 FMs. <sup>-Note:</sup> (The above list was based on its impact power, from high to low). (b) The findings of this investigation revealed: 'Gender' and 'Goal-setting' are not the determination aspects; but the 'Supporting' and Countries' aspect are. Which means: to maintain and improve the YVPs' engagement motivations level, coaches and instructors who working in the youth volleyball programs need to make sure there are enough supports from parents and schools; increasing meaningful interaction activities between the PRC and USA, learn from one another as well. (c) The findings discovered that: the 'Intrinsic factors' possess noteworthy higher impact power than the 'Extrinsic factors'. Such as: MF1 'Technical content & unique value' and MF4 'For enjoyments' possess the highest impact power on these youth volleyball player's motivations. (d)

Some MFs possess less impact power, such as: MF12 ‘To improve reputation’, MF15 ‘To reduce pressure’, and MF19 ‘To satisfy family’s will’; it did not mean these MFs can be ignored. Youth volleyball educators need to base on profounder diagnosis and analysis on their players’ situations and utilize these research findings correspondingly. (e) With regarding to the health related behaviors, although there is room for improving, it should be able to conclude that the grand mean score of the participants’ health related behaviors should be located in between the position of ‘Very good -4’ and ‘Good’ -3’ if using a four points assessment scale.

### 5.1. Recommendations

The current study explored the youth volleyball players' engagement motivations and health related behaviors. From other perspective, team atmosphere and good relationship between coaches and players also influenced youth players' engagement motivations. Although the values of youth players' engagement motivations have been recognized by some youth sports researchers (Miguel, Machar, 2007; Smith et al., 2006; Lippitt, 2012; Zeng, Meng, 2017). Further studies, however, are certainly needed, especially in the area of how the intrinsic motivation and extrinsic motivation work differently on different types of youth volleyball players, such as: 1) players who set up their goal ‘to become professional’ or ‘to be a non-professional’; 2) players who are financing support by-school or by parents (Lippitt, 2012); and 3) different gender of the players. Additionally, those health-related behaviors been explored in the current study could be another research topic, it deserves researchers who have interests in youth sports to pay attention, because only those youth players who have developed their positive health-related behaviors during their youth years have chance to become future volleyball stars and make their sport-star dream come true.

### 5.2. Application in youth sport

The findings of this study added a set of new data and information regarding the essential reasons / factors that truly motivated the youth volleyball players engaging in practices and competitions, and unique features about these players' health related behaviors as well. These findings can be lively examples and meaningful evidences to apply to youth sports educational programs. If this can be done that will lead better teaching, coaching and managing in youth sports.

### 6. Acknowledgements

The author is thankful to the City University of New York Research Fund for the support under the Grant (PSC-CNY Research Award, contract No. PSC-CNY Award # 60702-00 circle 48) for the project Scientific publications management. I want to express the deepest appreciation here! For the following coaches / administrators and for their remarkable helps that they have provided to this research project during the data collection. They are: Coaches Xie Li Sheng, Jose Garcia, Andria Cuello, Christ Gigliello, Jonathan Skelly, Steven Riveras, Danielle Mollo-Siano, and Director Wen-Yan Meng.

### 7. Conflict of interest statement

The author declares that there is no conflict of interest regarding the publication of this paper.

### References

- Bellis, 2013 – Bellis, M. (2013). Invention and History of Volleyball. Retrieved from <https://www.thoughtco.com/invention-and-history-of-volleyball-william-morgan-1992597/>
- Breese, 1998 – Breese, H.P. (1998). Participation motivation in ITFNFZ Taekwon-Do: A study of the central districts region. Massey University, NZ.
- Child, 1990 – Child, D. (1990). The essentials of factor analysis, second edition. London: Cassel Educational Limited.
- Chinese Middle School..., 2017 – China Middle School Sports Association (2017). Main duties and Business scope. Retrieved from <https://baike.baidu.com/item/%E4%B8%AD%E5%9B%BD%E4%B8%AD%E5%AD%A6%E7%94%9F%E4%BD%93%E8%82%B2%E5%8D%8F%E4%BC%9A>
- Claver et al., 2017 – Claver, F., Jiménez. R., Gil-Arias, A., Moreno, A., Moreno, M.P. (2017). The Cognitive and Motivation Intervention Program in Youth Female Volleyball Players. *J. Human*

*Kinetics*, 59: 55-65.

Cox, 2011 – Cox, R.H. (2011). *Sport Psychology: Concepts and Application*. Brown & Benchmark, Dubuque.

Deci, Ryan 1985 – Deci, E.L., Ryan, R. M. (1985). *Intrinsic Motivation and Self-Determination in Human Behavior*. New York: Plenum.

Deci, Ryan, 2002 – Deci, E.L., Ryan, R.M. (2002). Self-determination research: Reflections and future directions. In ELDyRM Ryan, (Ed.). *Handbook of self-determination research*, Rochester, NY: University of Rochester Press.

Devine, Lepisto, 2005 – Devine, R., Lepisto, L. (2005). Analysis of the healthy lifestyle consumer. *J. Consumer Marketing*, 22, 275-283. Retrieved from <http://dx.doi.org/10.1108/07363760510611707>

Ducksters, 2015 – Ducksters (2015). Volleyball Player Positions. Retrieved from <http://www.ducksters.com/sports/volleyballplayerpositions.php>

FIBV 2018 – FIBV (2018). International Volleyball Federation. Retrieved from <https://www.olympic.org/international-volleyball-federation>

Frank, 2015 – Frank, D. (2015). Volleyball Scholarships. College Volleyball Recruiting. Retrieved from <https://www.athleticscholarships.net/history-of-volleyball.html>

Geidne et al., 2013 – Geidne, S., Quennerstedt, M., Eriksson, C. (2013). The youth sports club as a health-promoting setting: An integrative review of research. *Scand J Public Health*, 41: 269–283.

Harter, 1981 – Harter, S. (1981). A new self-report scale of intrinsic versus extrinsic orientation in the classroom: Motivational and informational components. *Developmental Psychology*, 17: 300-312.

Kaplan, 2010 – Kaplan, A. (2010). Intrinsic and Extrinsic Motivation. Retrieved from <http://www.Education.com/reference/article/intrinsic-and-extrinsic-motivation/#>

Lippitt, 2012 – Lippitt, E. (2012). Motivation, Need Support and Need Satisfaction in Youth Soccer Players. Georgia Southern University, Statesboro, Georgia.

Miguel, Machar, 2007 – Miguel, C., Machar, M.R. (2007). Motivation in tennis. *British J. Sports Medicine*, 41: 769-772.

New York State..., 2017 – New York State Public High School Athletic Association (2017). Retrieved from <http://www.nysphsaa.org/About-NYSPHSAA/General-Information/Who-We-Are>

Official Report, 2010 – Official Report (2010). The official report: Singapore 2010 Youth Olympic Games. Retrieved from <https://www.olympic.org/singapore-2010>

Pintrich, Schunk, 2002 – Pintrich, P.R., Schunk, D. (2002). *Motivation in education: Theory, research and applications* (Second ed.). Upper Saddle River, NJ: Prentice-Hall.

Public Schools Athletic... 2017 – Public Schools Athletic League. (2017). The mission of the PSAL. Retrieved from <http://www.psal.org/articles/article-detail.aspx#26329>

Ryan, Deci, 2000 – Ryan, R.M., Deci, E.L. (2000). Self-determination theory and the facilitation of intrinsic motivation, social development, and well-being. *American Psychologist*, 55: 68–78.

Ryan et al, 1997 – Ryan, R.M., Frederick, C.M., Lepas, D., Rubio, D., Sheldon, K.S. (1997). Intrinsic motivation and exercise adherence. *International J. Sports Psychology*, 28: 355-354.

Smith et al., 2006 – Smith, A.L., Balagurer, I., Duda, J. L. (2006). Goal orientation profile differences on perceived motivational climate, perceived peer relationships, and motivation-related responses of youth athletes. *J. Sports Sciences*, 24: 1315-1327.

Stipek, 1996 – Stipek, D.J. (1996). Motivation and instruction. In D. C. Berliner & R. C. Calfee (Eds.), *Handbook of educational psychology*, pp. 85–113. New York: Macmillan.

Wikipedia, 2018 – Wikipedia (2018). China women's national volleyball team. Retrieved from [https://en.wikipedia.org/wiki/China\\_women%27s\\_national\\_volleyball\\_team](https://en.wikipedia.org/wiki/China_women%27s_national_volleyball_team)

Zeng et al., 2015 – Zeng, Z.H., Cynarski, W.J., Baatz, S., Shawn, P.J. (2015). A study of Taekwondo Students' Motivation from New York. *World J. Education*, 5: 51-63.

Zeng, Meng, 2017 – Zeng, Z.H., Meng, W.Y. (2017). An Investigation of Youth Basketball Players' Participation Motivations and Relate Elements. *J. International Applied psychology*, 7: 86-95.

Zeng et al, 2016 – Zeng, Z.H., Xie, L.S., Meng, W.Y. (2016). A Study of Youth Soccer Athletes' Motivation from Jiangsu China. Paper presented in the 2016 SHAPE America National Convention and Exposition in Minneapolis, MN.